

Contents

1 Diatonic

- Ionian
- Dorian
- Phrygian
- Lydian
- Mixolydian
- Aeolian
- Locrian

2 Harmonic Minor

- Harmonic Minor Αρμονικό μινόρε
- Locrian #6 Kalingada Raga
- Ionian Aug هزَام (Huzam)
- Romanian Ποιμενικός (Pimenikos)
- Phrygian Dom Χιτζάζ (Hitzaz)
- Lydian #2
- Ultralocrian

3 Harmonic Major

- Harmonic Major
- Dorian b5 Καρτσιγάρ (Kartsigar)
- Phrygian b4
- Lydian b3 Νικρίζ (Nikriz)
- Mixolydian b9 Ουζάλ (Ouzal)
- Lydian Aug #2
- Locrian bb7

4 Melodic Minor

- Jazz Minor Melodic Minor
- Dorian b9
- Lydian Aug
- Lydian Dom
- Mixolydian b6
- Semilocrian
- Superlocrian

5 Double Harmonic Major

- Double H. Major Χιτζαζκιάρ (Hitzazkiar)
- Lydian #2 #6
- Ultraphrygian
- Hungarian Minor نوى أثر (Nawa Athar)
- Oriental
- Ionian Aug #2
- Locrian bb3 bb7

6 Bebop Major

- 7 Bebop Minor
- 8 Bebop Dominant
- Bebop Dominant
- Bebop Locrian
- Bebop Dorian
- 9 Hungarian
- 10 Neapolitan

11 Neapolitan Minor

- Neapolitan Minor
- Σουζινάκ (Souzinak)
- Χουζάμ (Houzam)

12 صبا (Saba)

13 Σαμπάχ (Sabac)

14 Ταμπαχανιώτικος / Pelog

- Ταμπαχανιώτικος (Tampacaniotikos)
- Pelog Selisir
- Pelog Tembung
- Pelog Sunaren

15 Σεγκιάχ (Segkiac) / Miaki Todi Raga

- Σεγκιάχ
- Miaki Todi Raga
- Persian

16 Marwa Raga / Blues Scale

- Marwa Raga
- Blues Scale

17 Purvi Swar Raga / Lalith Raga

18 Purvi Raga

19 Gujari Todi Raga

Diatonic

Scale Degree

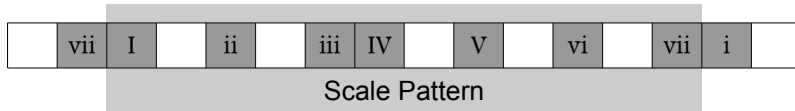

I	Major $\Delta 7$
II	Minor -7
III	Minor -7
IV	Major $\Delta 7$
V	Major 7
VI	Minor -7
VII	Minor d5 -7

Modes \rightarrow
 \leftarrow Chords

I	Ionian
II	Dorian
III	Phrygian
IV	Lydian
V	Mixolydian
VI	Aeolian
VII	Locrian

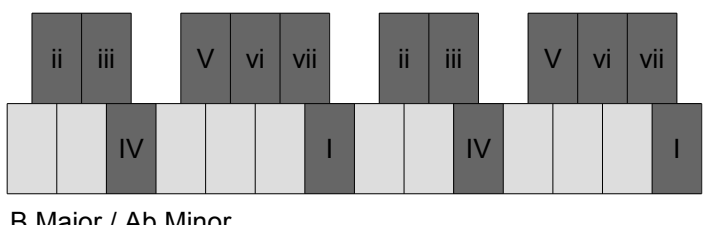
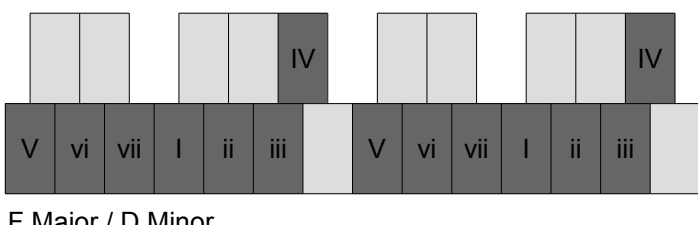
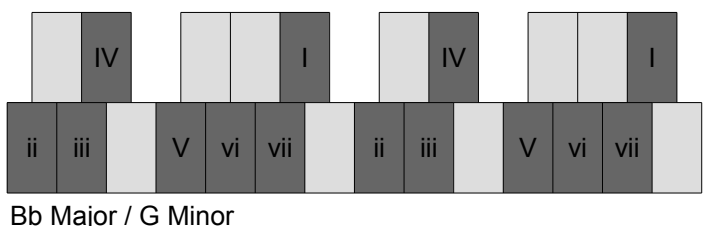
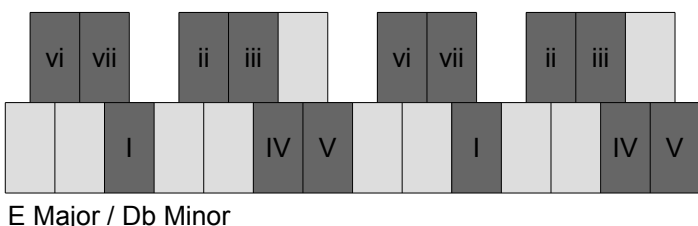
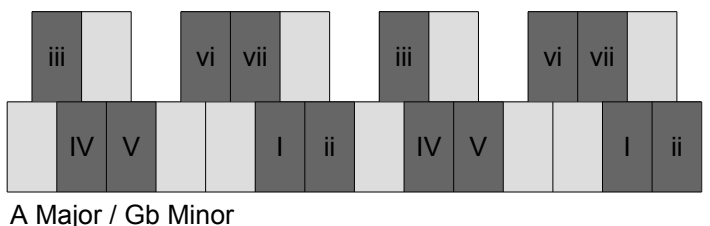
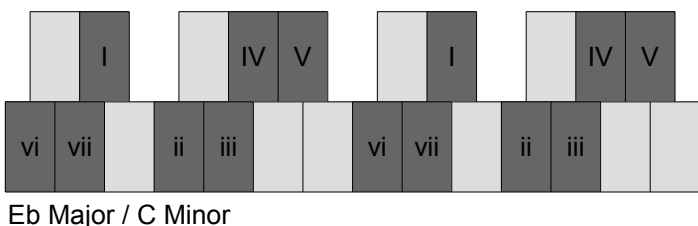
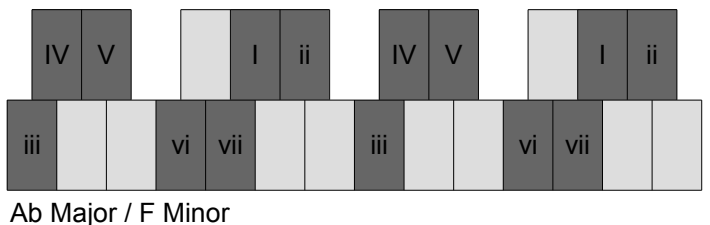
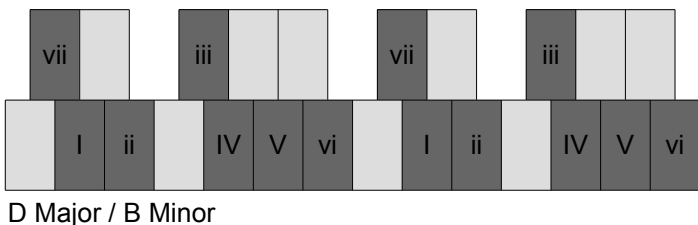
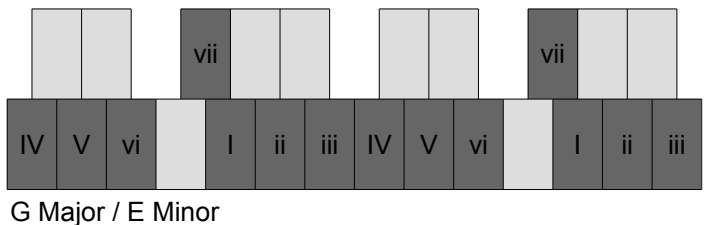
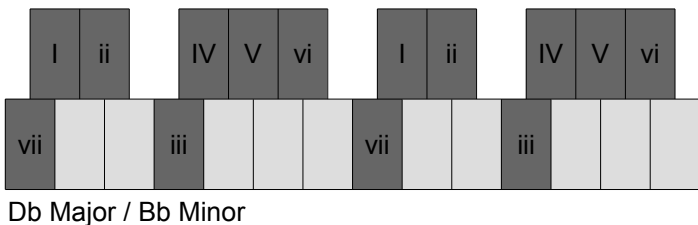
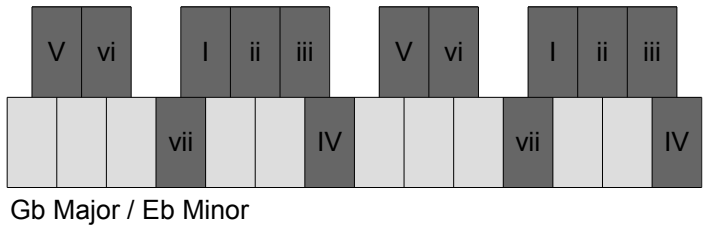
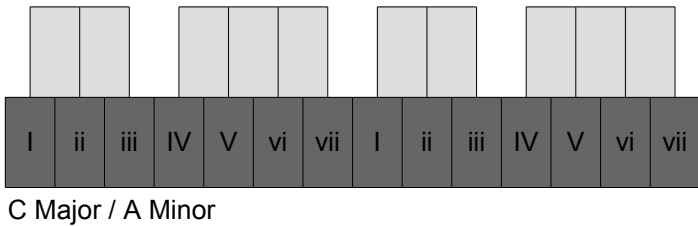

Harmonic Minor

Scale Degree

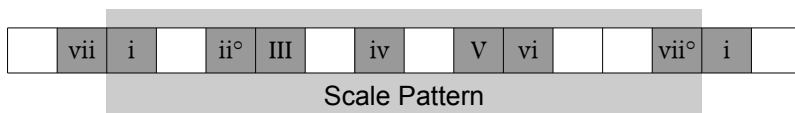

I	Minor / -Δ7
II	Minor ° / °-7
III	Major + / +Δ7
IV	Minor / -7
V	Major / 7
VI	Min/Maj / -Δ7 / Δ7
VII	Min/Maj ° / °6

Modes →
← Chords

I	Harmonic Minor
II	Locrian #6
III	Ionian Aug
IV	Romanian
V	Phrygian Dom
VI	Lydian #2
VII	Ultralocrian

or	Αρμονικό μινόρε (Armoniko minor)
or	Kalingada Raga → Vadi
or	هزام (Huzam)
or	Ποιμενικός (Pimenikos)
or	Χιτζάζ (Hitzaz)

D: 5th

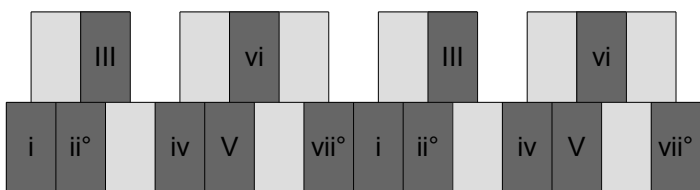

C Harmonic Minor

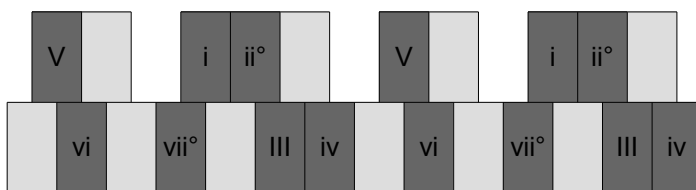

Gb Harmonic Minor

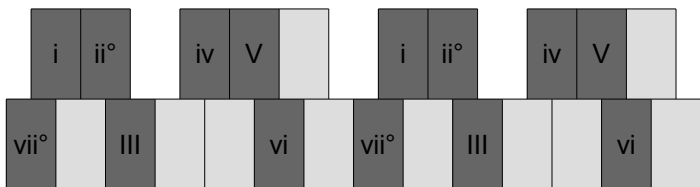

Db Harmonic Minor

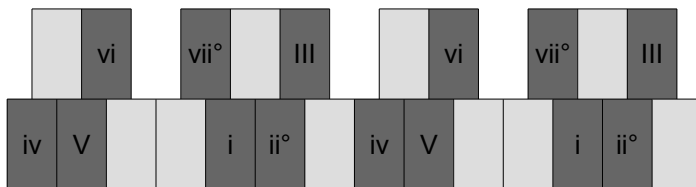

G Harmonic Minor

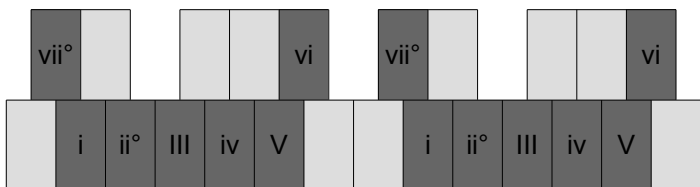

D Harmonic Minor

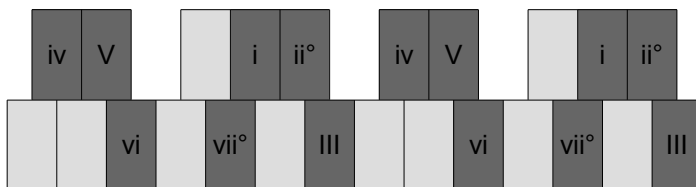

Ab Harmonic Minor

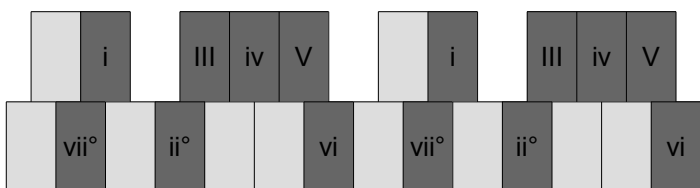

Eb Harmonic Minor

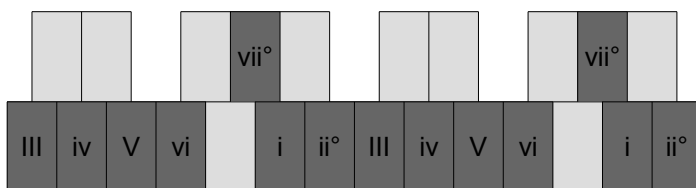

A Harmonic Minor

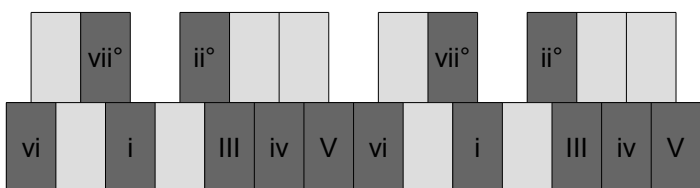

E Harmonic Minor

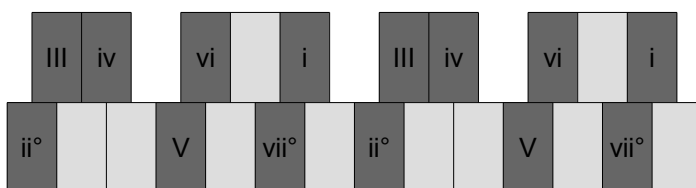

Bb Harmonic Minor

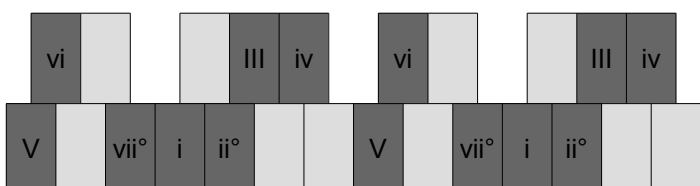

F Harmonic Minor

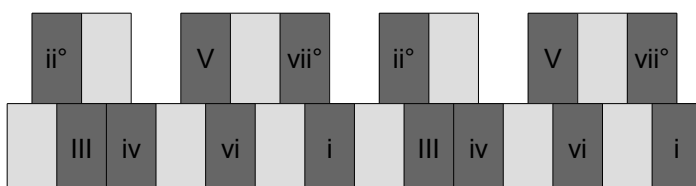

B Harmonic Minor

Harmonic Major

Scale Degree

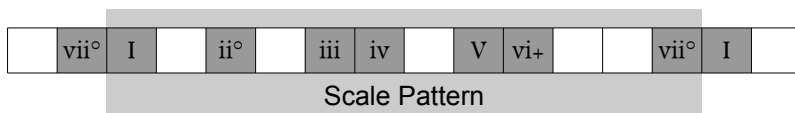

I	Major / Δ7
II	Minor ° / °-Δ7
III	Min/Maj / -7 / 7
IV	Minor / -Δ7
V	Major / 7
VI	Min/Maj + /+-Δ7 / +Δ7
VII	Min ° / -6°

Modes →
← Chords

I	Harmonic Major
II	Dorian b5
III	Phrygian b4
IV	Lydian b3
V	Mixolydian b9
VI	Lydian Aug #2
VII	Locrian bb7

or Καρτσιγάρ (Kartsigar)
or Νικρίζ (Nikriz)
or Ουζάλ (Ouzal)

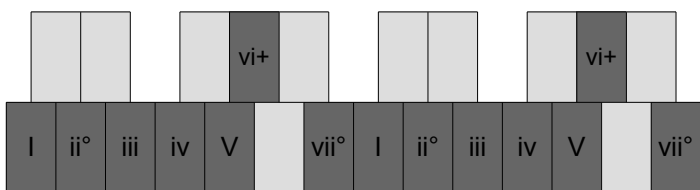

C Harmonic Major

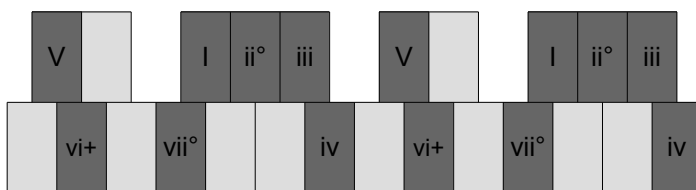

Gb Harmonic Major

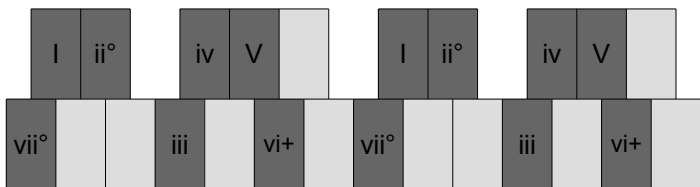

Db Harmonic Major

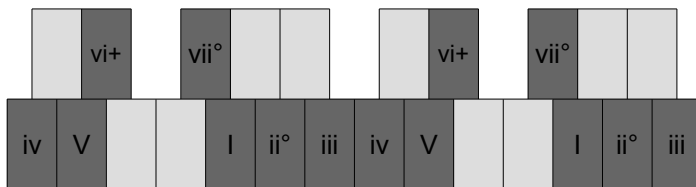

G Harmonic Major

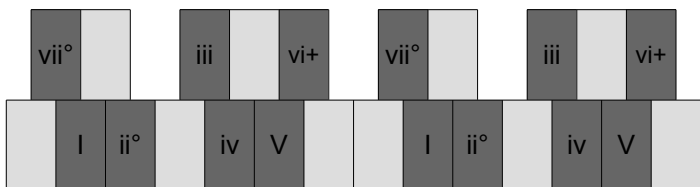

D Harmonic Major

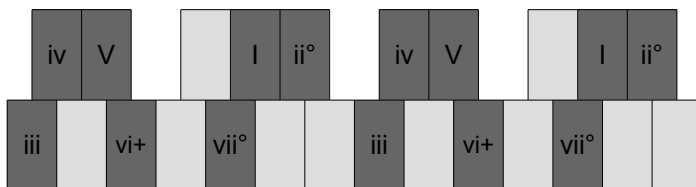

Ab Harmonic Major

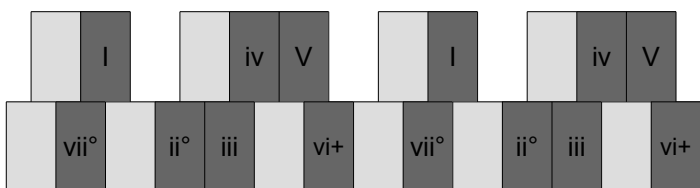

Eb Harmonic Major

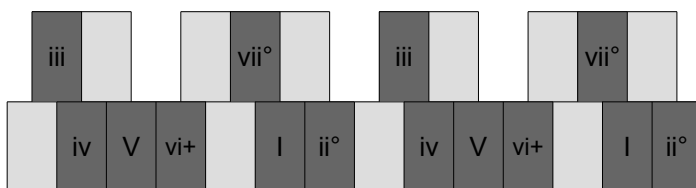

A Harmonic Major

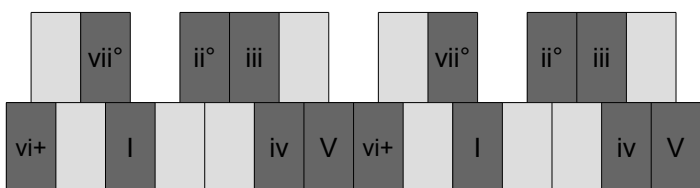

E Harmonic Major

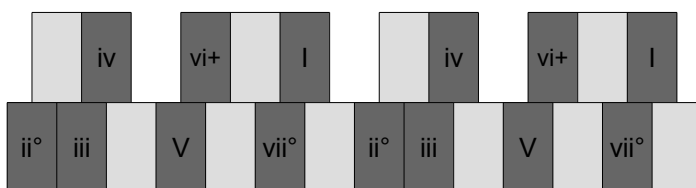

Bb Harmonic Major

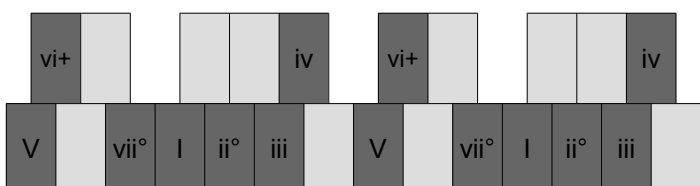

F Harmonic Major

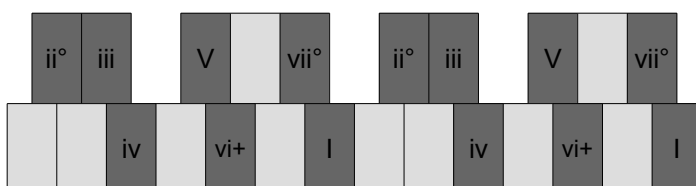

B Harmonic Major

Melodic Minor

Scale Degree

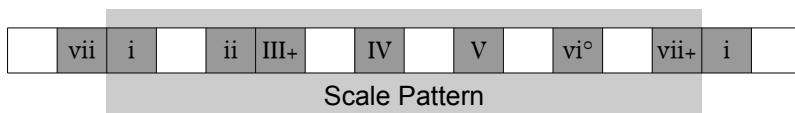

I	Minor / $-\Delta 7$
II	Minor / -7
III	Major + / $+\Delta 7$
IV	Major / 7
V	Major / 7
VI	Minor $^\circ$ / $^\circ-7$
VII	Min/Maj+ / $+7 / +7$

Modes →
← Chords

I	Jazz Minor	or	Melodic Minor
II	Dorian b9		
III	Lydian Aug		
IV	Lydian Dom		
V	Mixolydian b6		
VI	Semilocrian		
VII	Superlocrian		

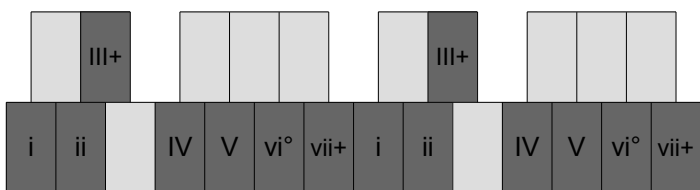

C Melodic Minor

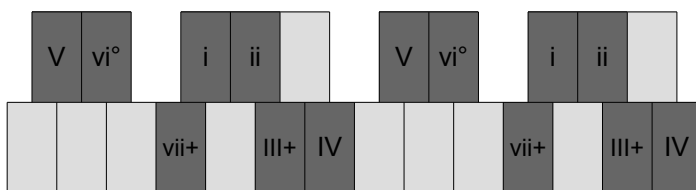

Gb Melodic Minor

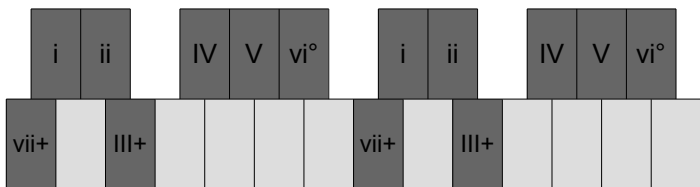

Db Melodic Minor

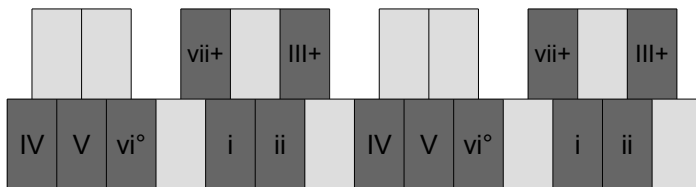

G Melodic Minor

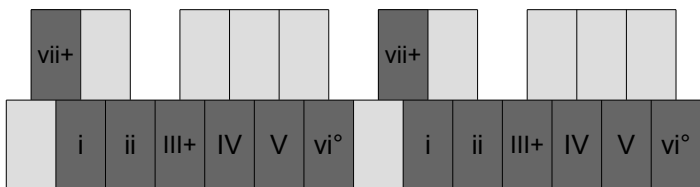

D Melodic Minor

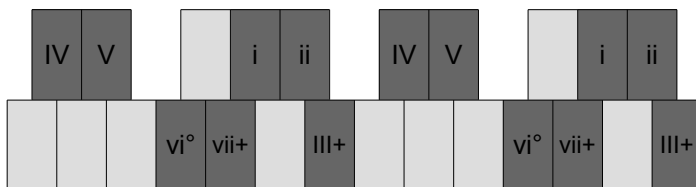

Ab Melodic Minor

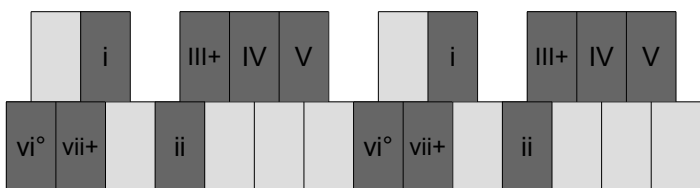

Eb Melodic Minor

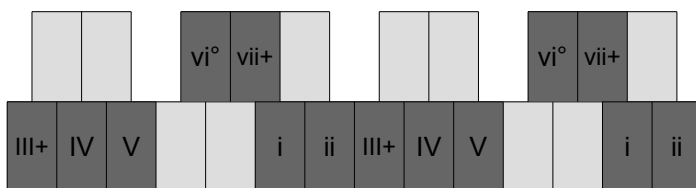

A Melodic Minor

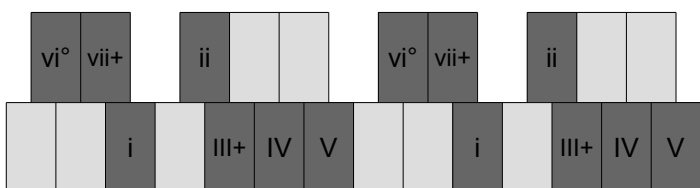

E Melodic Minor

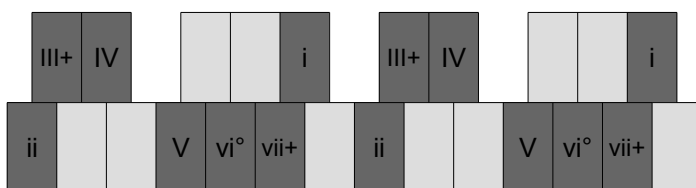

Bb Melodic Minor

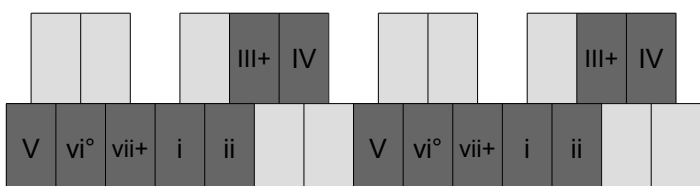

F Melodic Minor

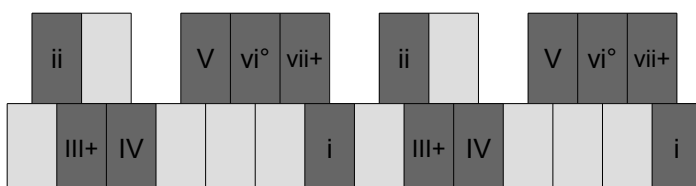

B Melodic Minor

Double Harmonic Major

Scale Degree

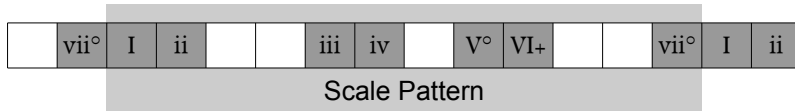

Bhairav Raga

or **Χιτζαζικιάρ (Hitzazkiar)** D: 5th
SmV

or **نوی آثر (Nawa Athar)**

Vadi

I	Major / Δ7
II	Min/Maj / Δ7/-Δ7/7/-7
III	Min/Maj / 6 / -6
IV	Min / -Δ7
V	Maj ° / °7
VI	Min/Maj + / +-Δ7 / +Δ7
VII	° Sus2

Modes →

← Chords

I	Double H. Major
II	Lydian #2 #6
III	Ultraphythgian
IV	Hungarian Minor
V	Oriental
VI	Ionian Aug #2
VII	Locrian bb3 bb7

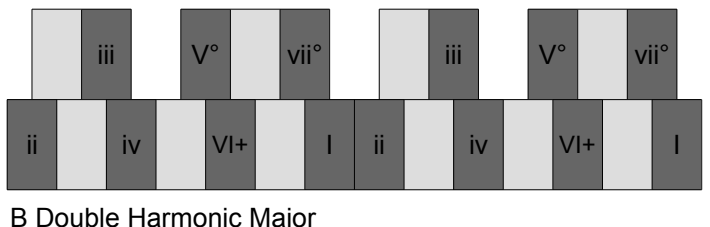
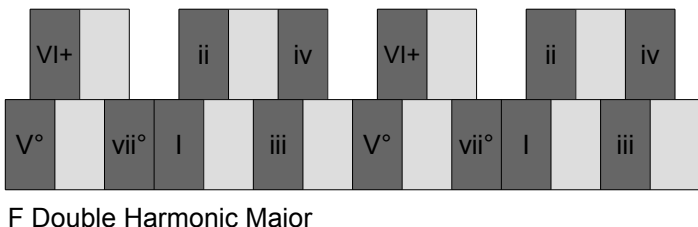
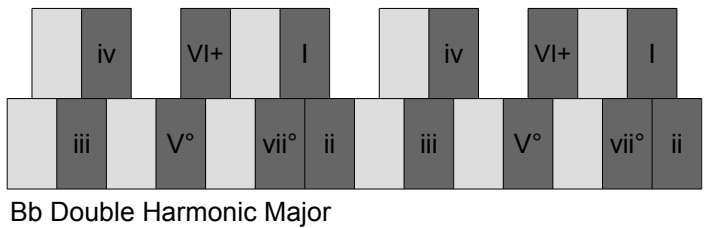
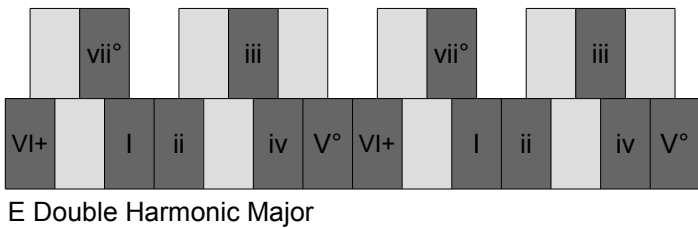
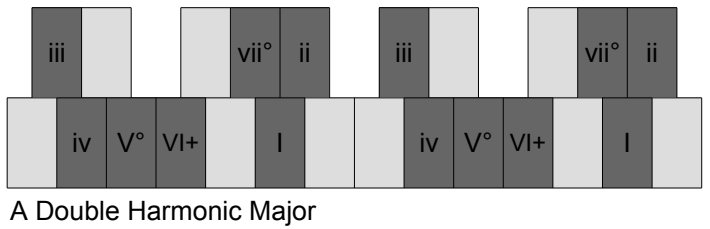
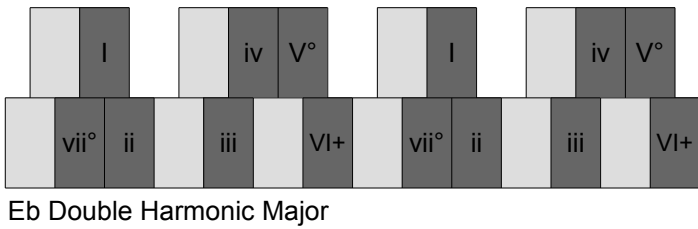
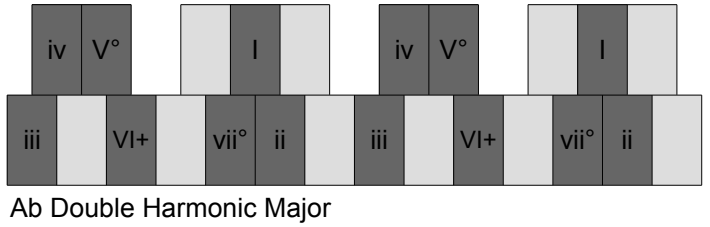
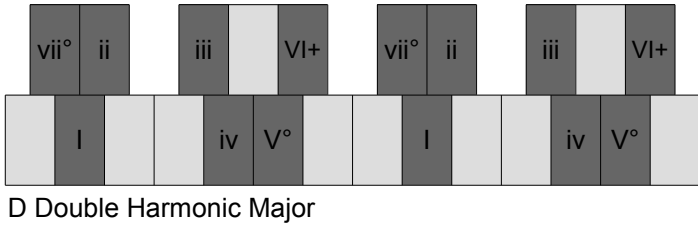
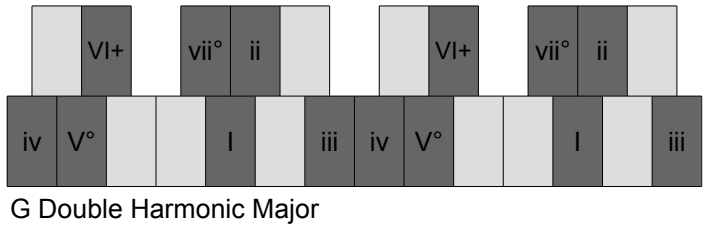
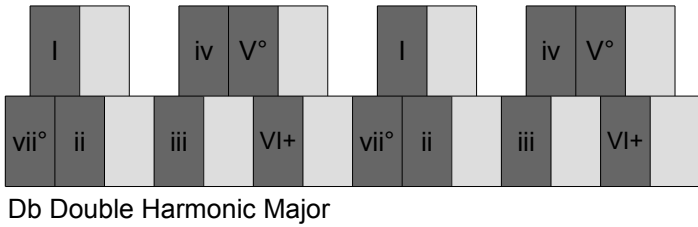
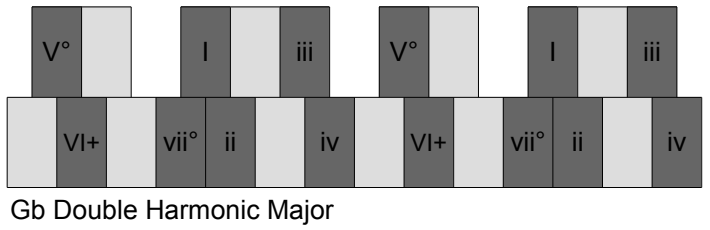
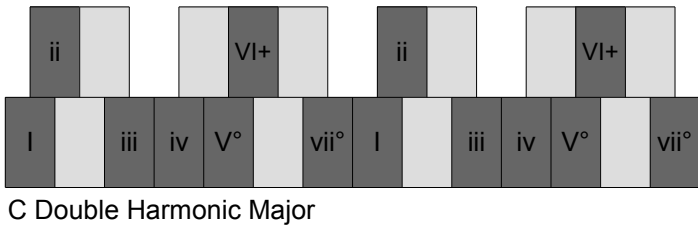

Bebop Major

Scale Degree

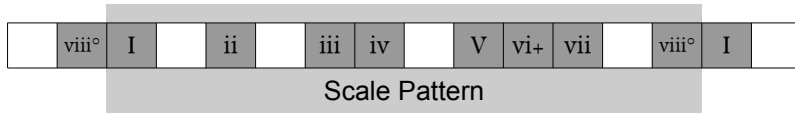

I	Major / $\Delta 7$
II	Minor / -7
III	Min/Maj / 7 / -7
IV	Min/Maj / $\Delta 7$ / $-\Delta 7$
V	Major / 7
VI	Min/Maj + / $+\Delta 7$ / $+\Delta 7$
VII	Minor / $-\Delta 7$ / -7
VIII	Min ° / °-7

Modes →
← Chords

I	Bebop Major
II	
III	
IV	
V	
VI	
VII	
VIII	

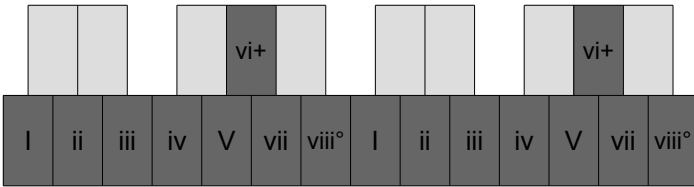

C Bebop Major

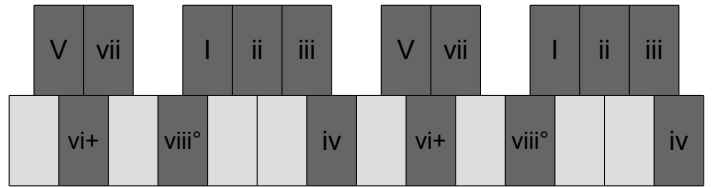

Gb Bebop Major

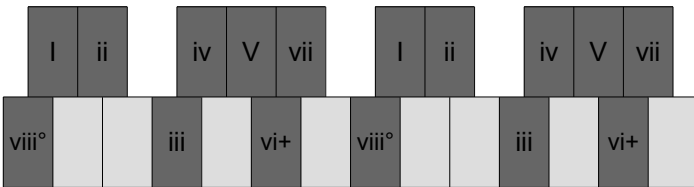

Db Bebop Major

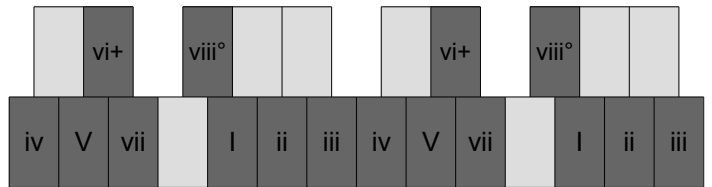

G Bebop Major

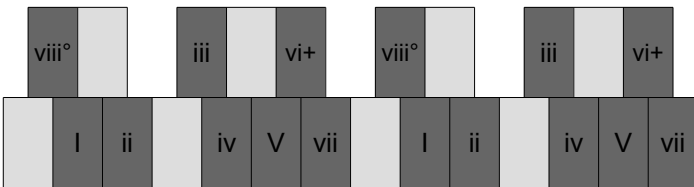

D Bebop Major

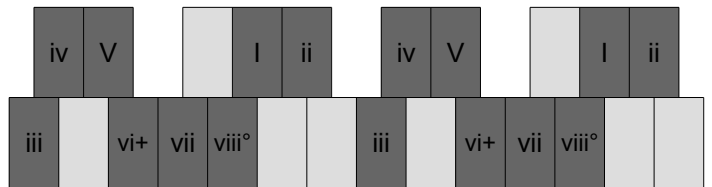

Ab Bebop Major

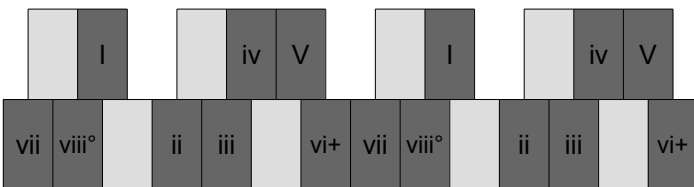

Eb Bebop Major

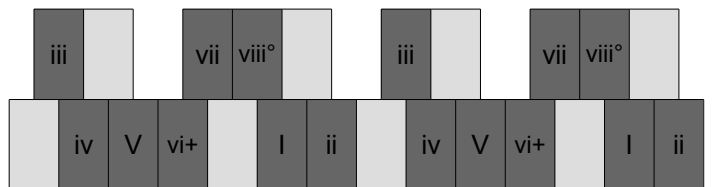

A Bebop Major

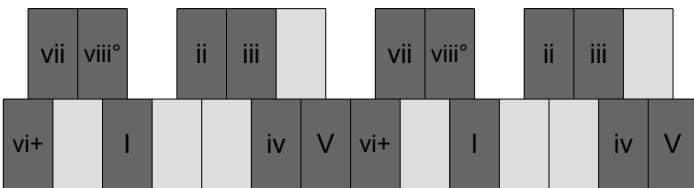

E Bebop Major

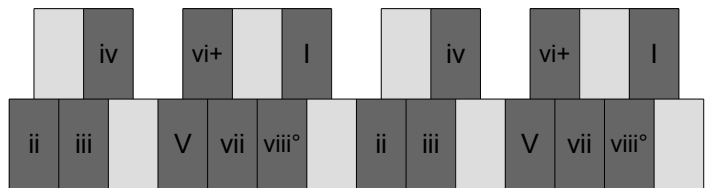

Bb Bebop Major

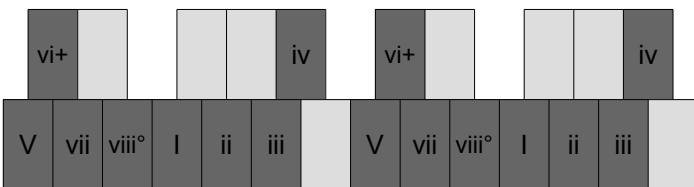

F Bebop Major

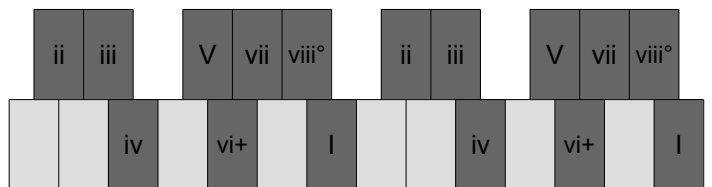

B Bebop Major

Bebop Minor

Scale Degree

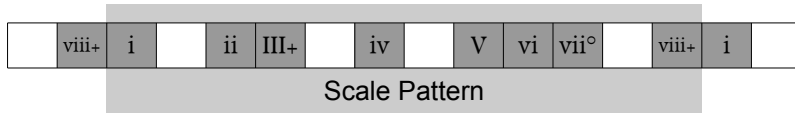

I	Minor / -Δ7
II	Minor / -7
III	Major + / +Δ7
IV	Min/Maj / -7 / 7
V	Major / 7
VI	Min/Maj / Δ7 / -Δ7
VII	Min ° / °-Δ7 / °-7
VIII	Min/Maj + / +7 / +-7

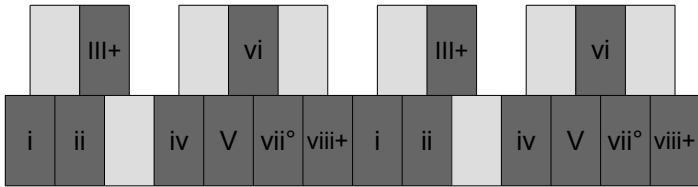
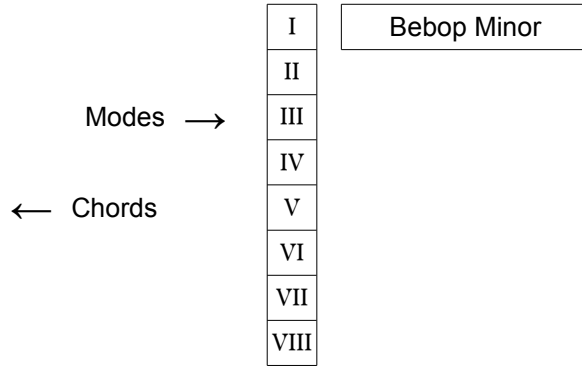

C Bebop Minor

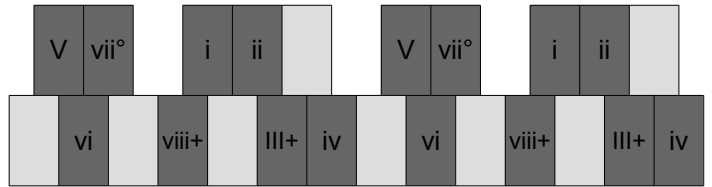

Gb Bebop Minor

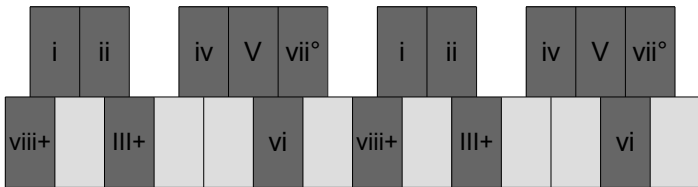

Db Bebop Minor

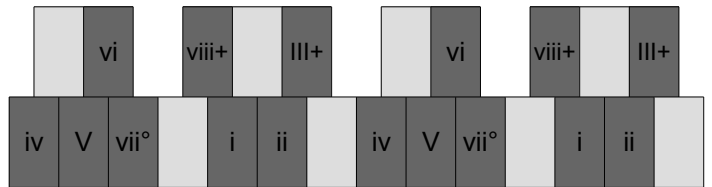

G Bebop Minor

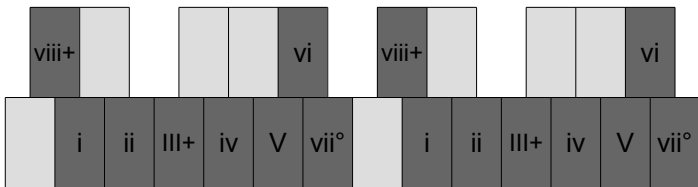

D Bebop Minor

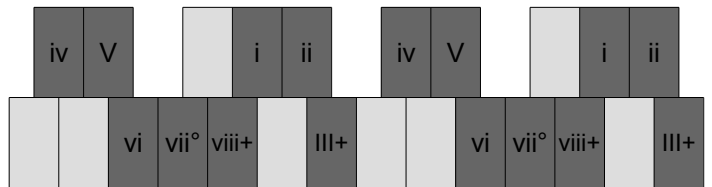

Ab Bebop Minor

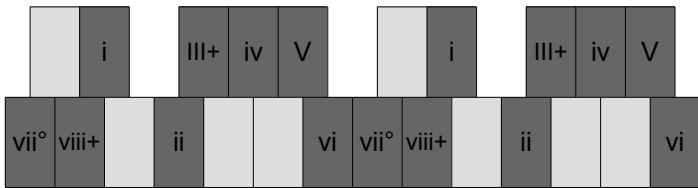

Eb Bebop Minor

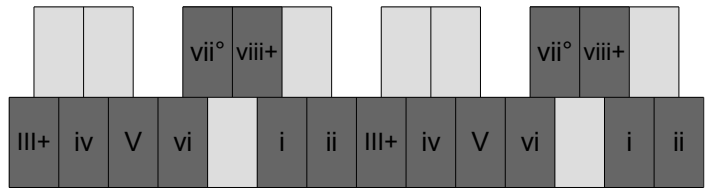

A Bebop Minor

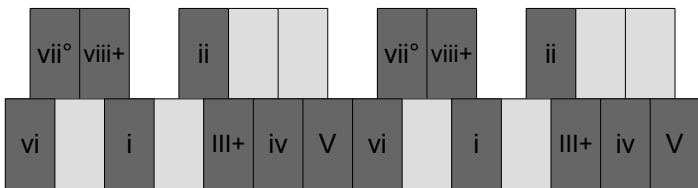

E Bebop Minor

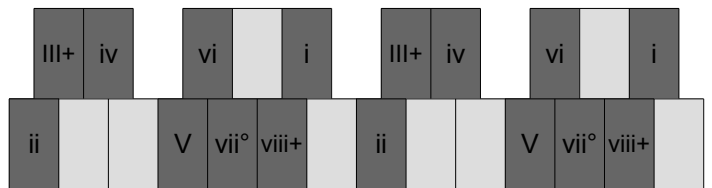

Bb Bebop Minor

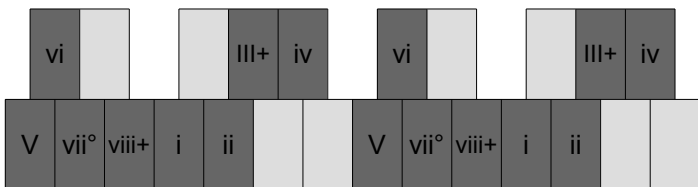

F Bebop Minor

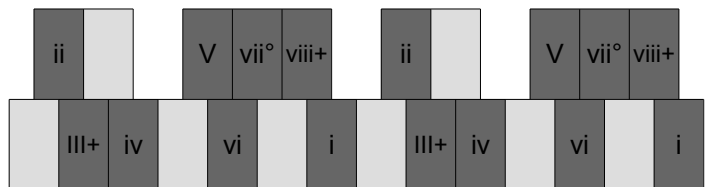

B Bebop Minor

Bebop Dominant

Scale Degree

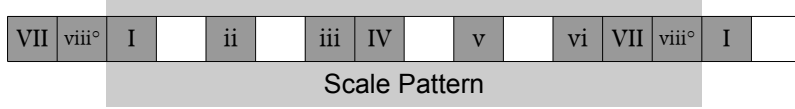

I	Major / Δ7 / 7
II	Minor / -7
III	Minor / -7
IV	Major / Δ7
V	Min/Maj / 7 / -7
VI	Minor / -7
VII	Major / Δ7
VIII	Min ° / °-7 / °-Δ7

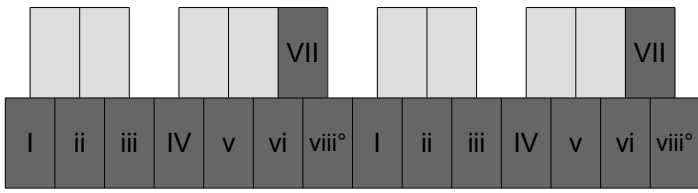
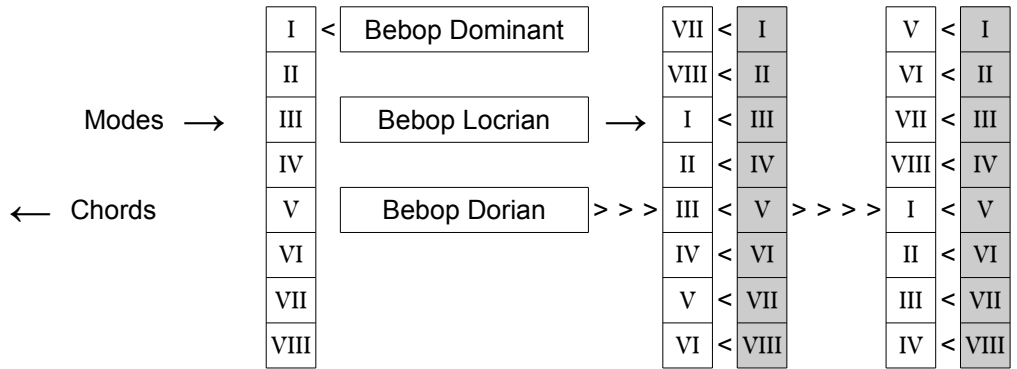

C Bebop Dominant

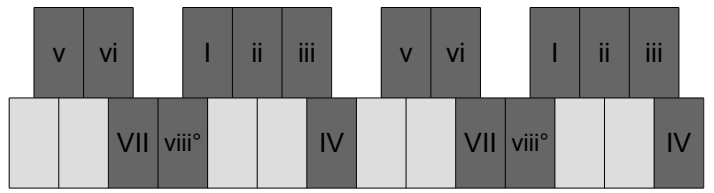

Gb Bebop Dominant

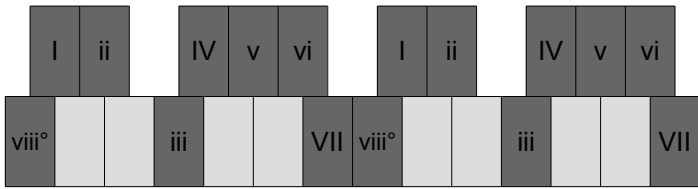

Db Bebop Dominant

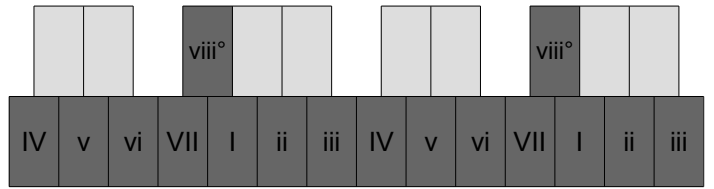

G Bebop Dominant

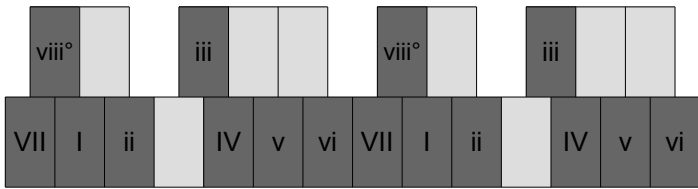

D Bebop Dominant

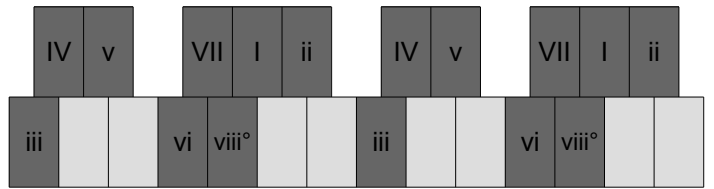

Ab Bebop Dominant

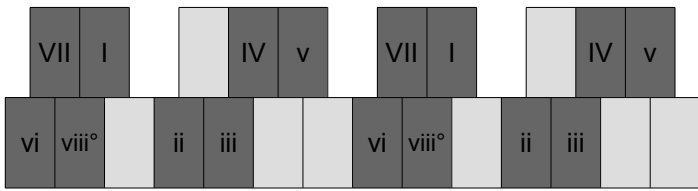

Eb Bebop Dominant

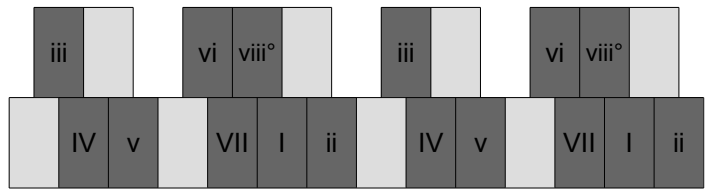

A Bebop Dominant

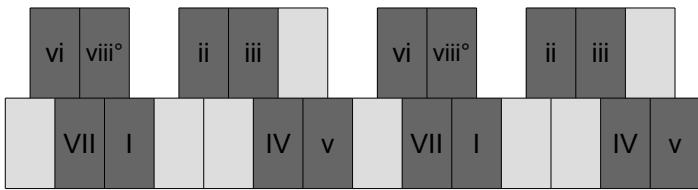

E Bebop Dominant

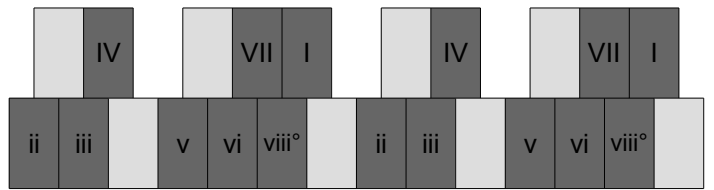

Bb Bebop Dominant

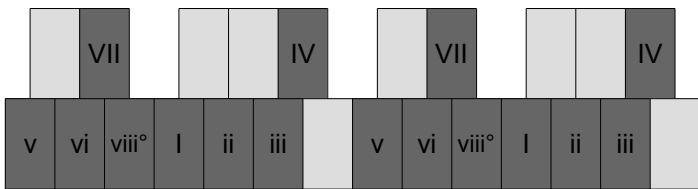

F Bebop Dominant

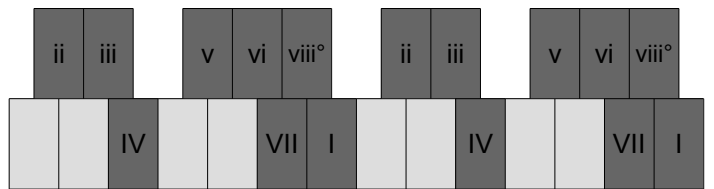

B Bebop Dominant

Hungarian

Scale Degree

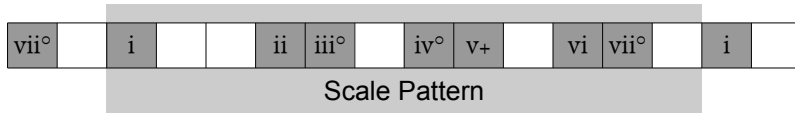

I	Min/Maj / 7 / -7
II	Min/Maj
III	Min ° / °-Δ7
IV	Min/Maj ° / °7 / °-7
V	Min + / +Δ7
VI	Minor / -7
VII	Sus2 °

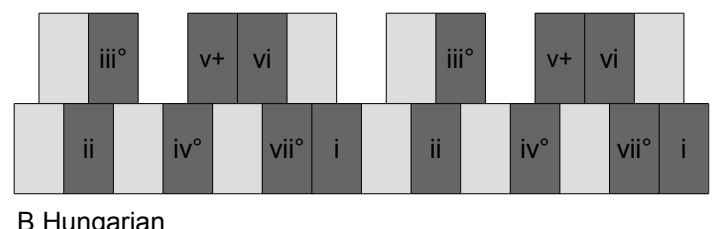
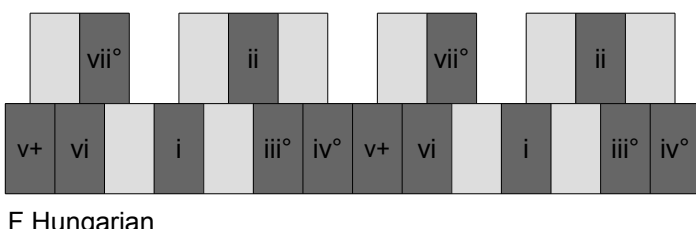
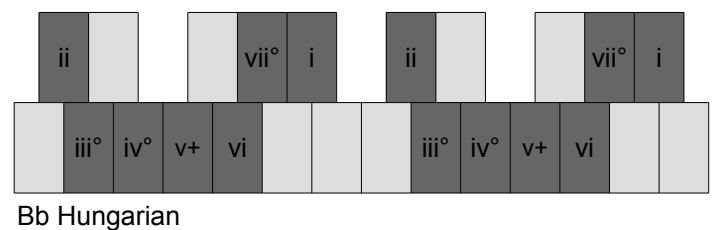
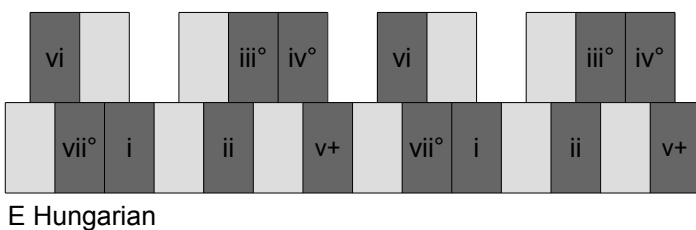
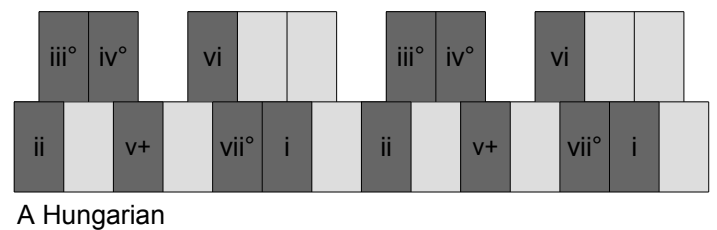
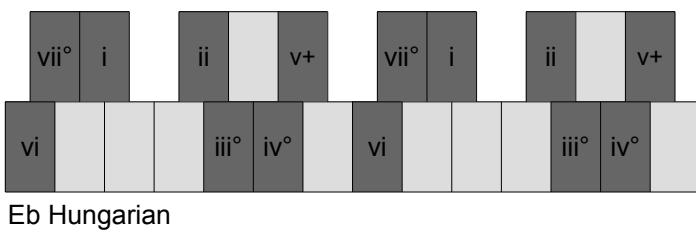
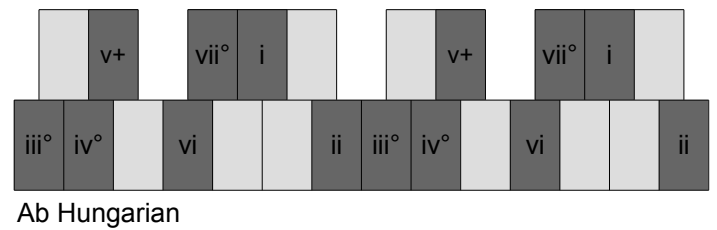
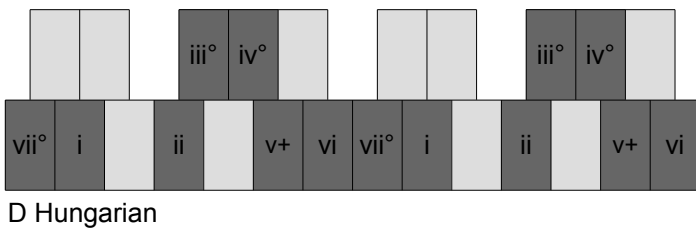
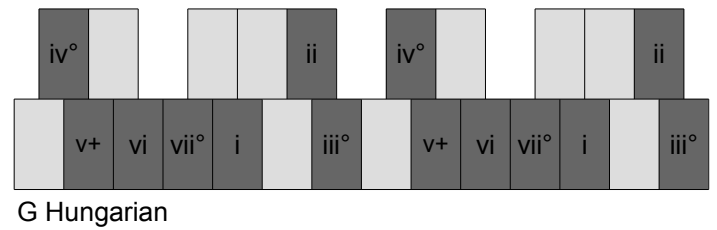
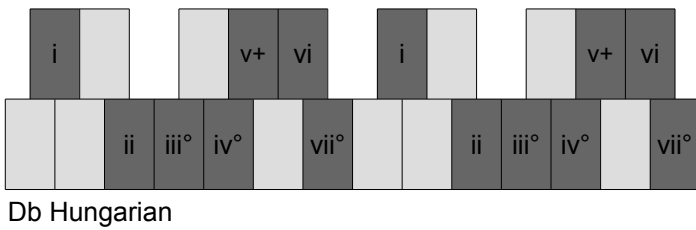
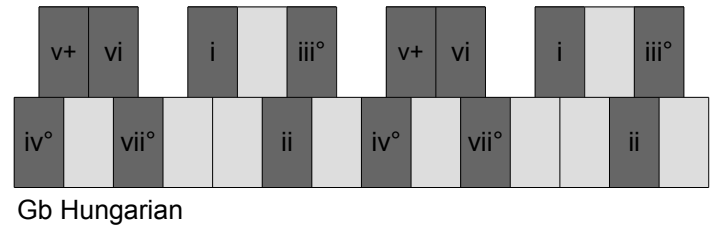
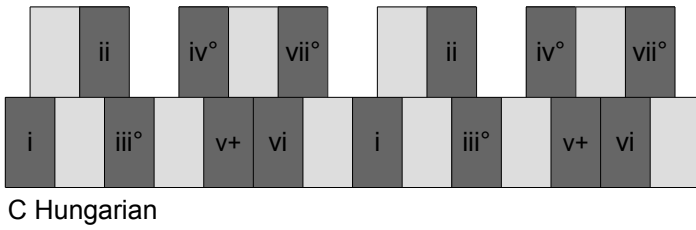
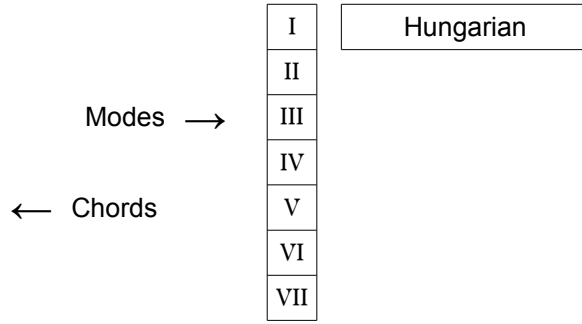

Neapolitan

Scale Degree

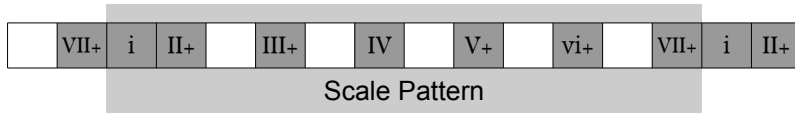

I	Minor / -Δ7
II	Major + / +7 / +Δ7
III	Major + / +7 / +-7
IV	Major / 7
V	Major + / +7
VI	Min/Maj + / +7 / +-7
VII	Major + / +7

Modes →
← Chords

I	Neapolitan
II	
III	
IV	
V	
VI	
VII	

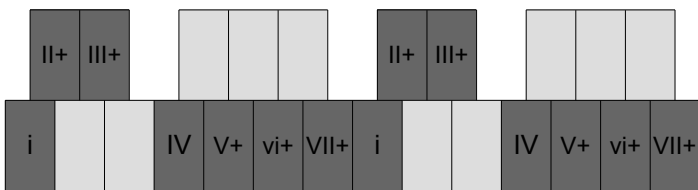

C Neapolitan

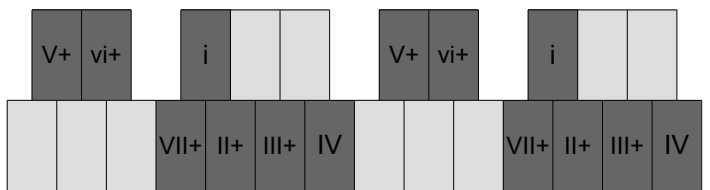

Gb Neapolitan

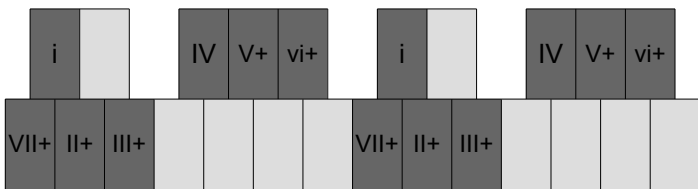

Db Neapolitan

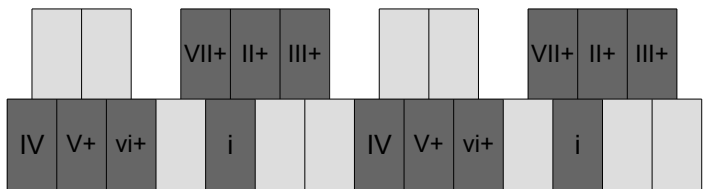

G Neapolitan

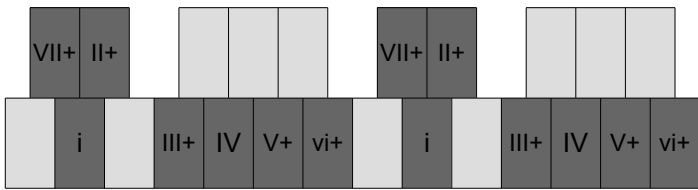

D Neapolitan

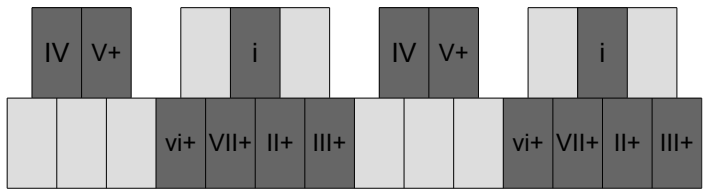

Ab Neapolitan

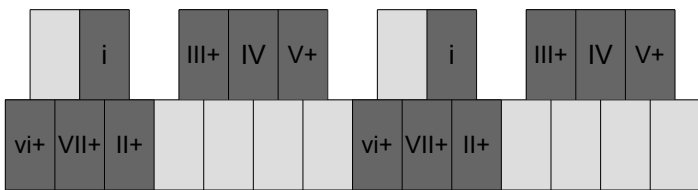

Eb Neapolitan

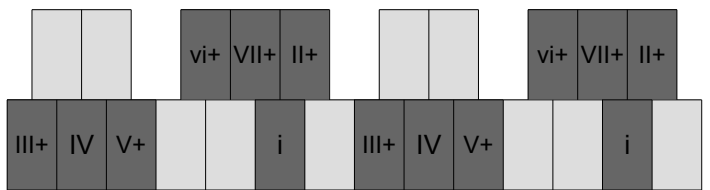

A Neapolitan

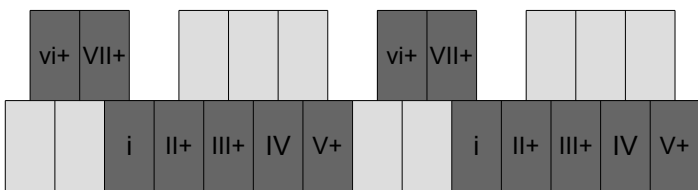

E Neapolitan

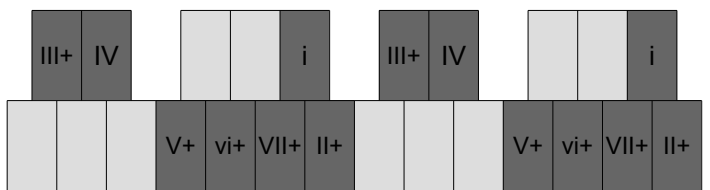

Bb Neapolitan

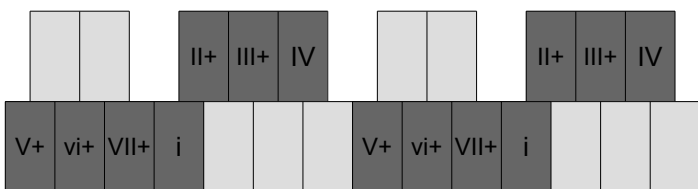

F Neapolitan

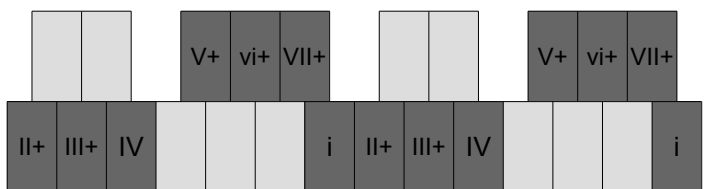

B Neapolitan

Neapolitan Minor

Scale Degree

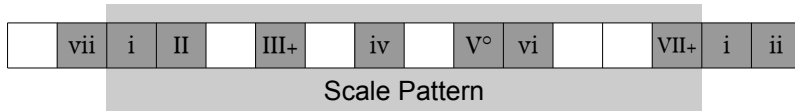

I	Minor / -Δ7
II	Major / 7 / Δ7
III	Major + / +7
IV	Minor / -7
V	Major ° / °7
VI	Min/Maj / -Δ7 / Δ7
VII	Major +

Modes →
← Chords

I	Neapolitan Minor
II	
III	
IV	Σουζινάκ (Souzinak)
V	
VI	Χουζάμ (Houzam)
VII	

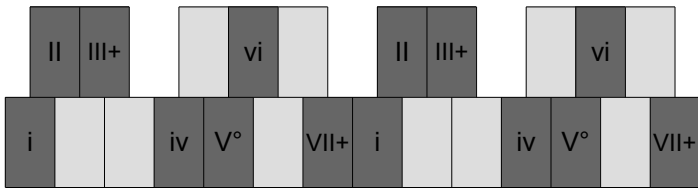

C Neapolitan Minor

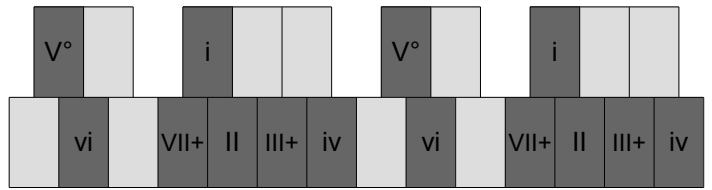

Gb

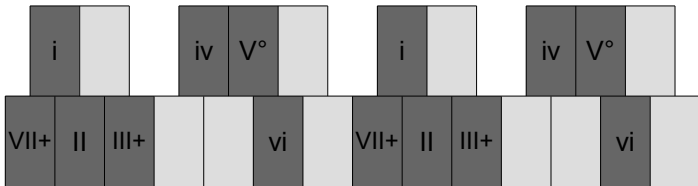

Db Neapolitan Minor

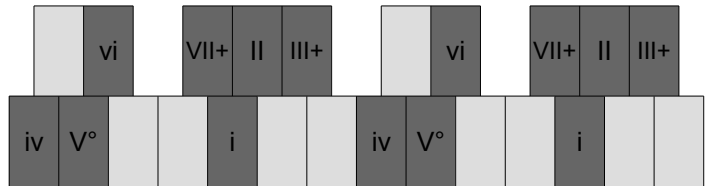

G Neapolitan Minor

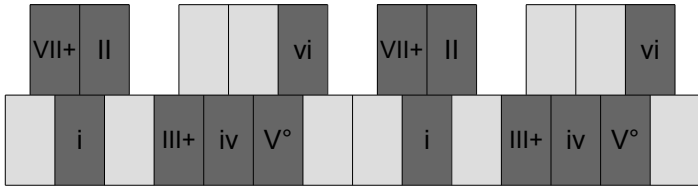

D Neapolitan Minor

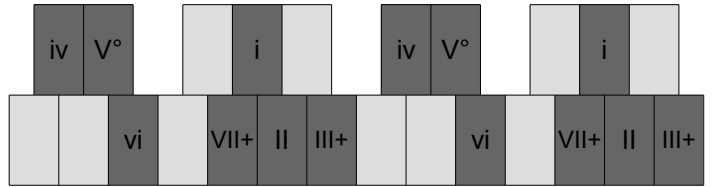

Ab Neapolitan Minor

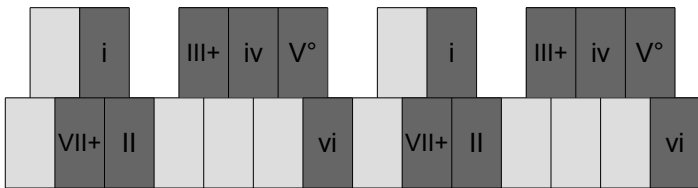

Eb Neapolitan Minor

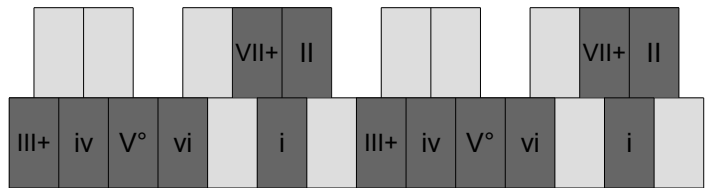

A Neapolitan Minor

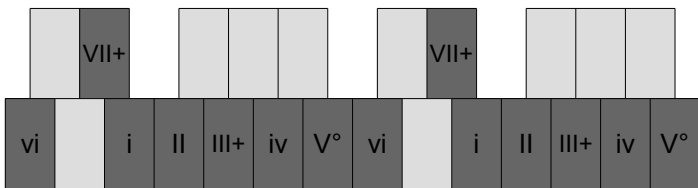

E Neapolitan Minor

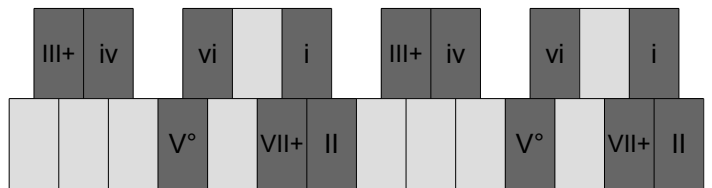

Bb Neapolitan Minor

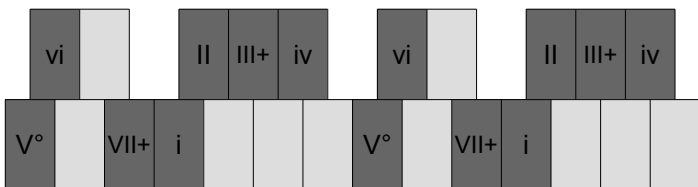

F Neapolitan Minor

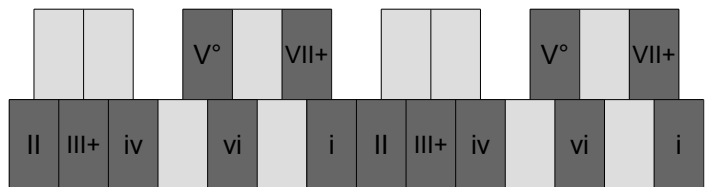

B Neapolitan Minor

صبا (Saba)

Scale Degree

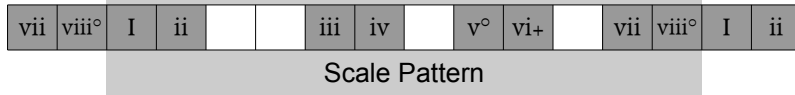

I	Major / Δ7 / 7
II	Min/Maj / Δ7/-Δ7/7/-7
III	Min/Maj
IV	Minor / -Δ7
V	Min/Maj ° / °7 / °-7
VI	Min/Maj + / +Δ7 / +-Δ7
VII	Minor / -7
VIII	Sus2 °

Modes →
← Chords

I	صبا (Saba)
II	
III	
IV	
V	
VI	
VII	
VIII	

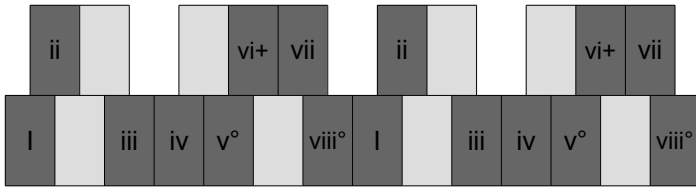

C صبا

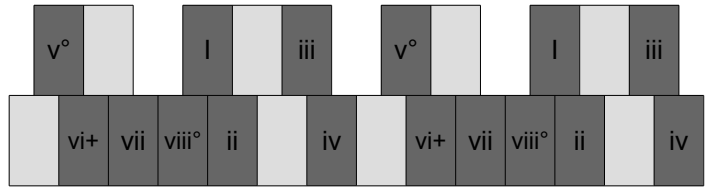

Gb صبا

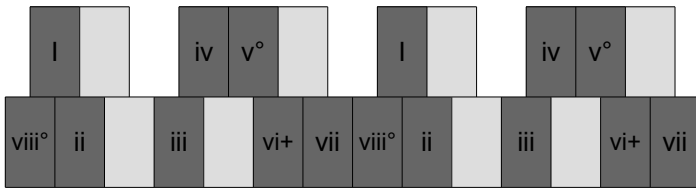

Db صبا

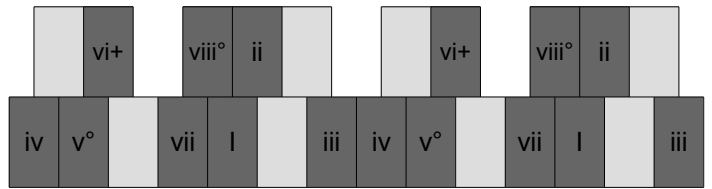

G صبا

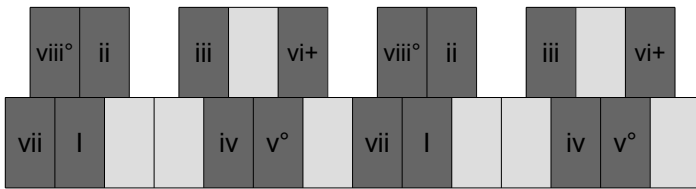

D صبا

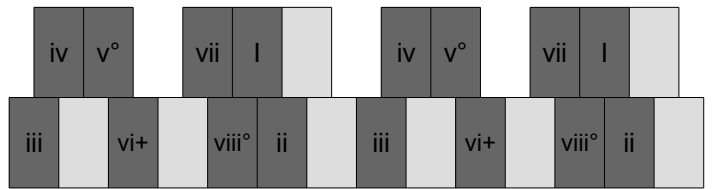

Ab صبا

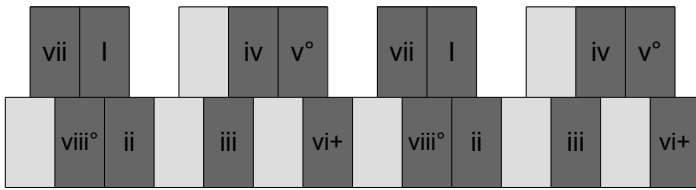

Eb صبا

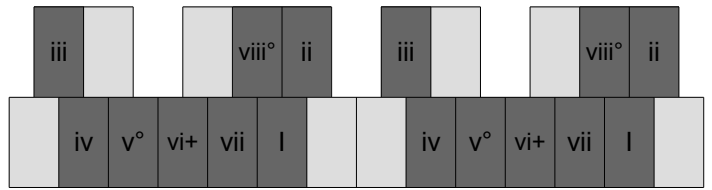

A صبا

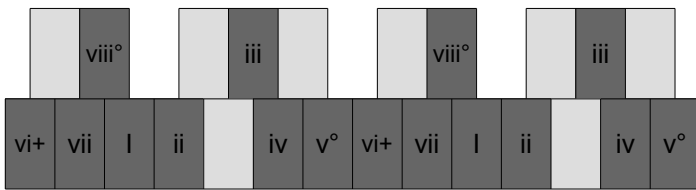

E صبا

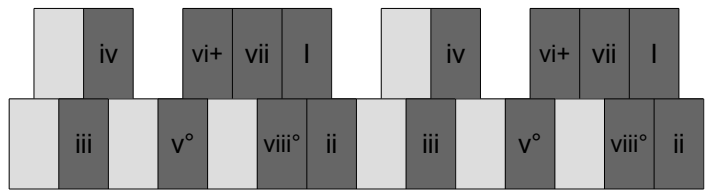

Bb صبا

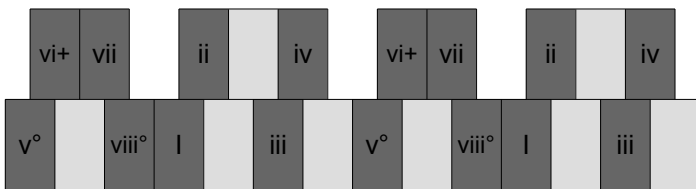

F صبا

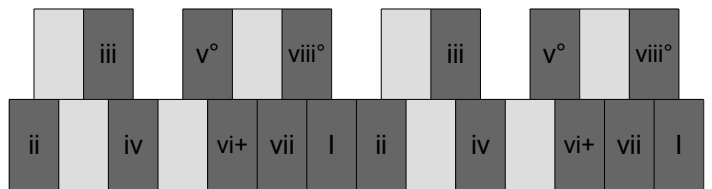

B صبا

Σαμπάχ (Sabac)

Scale Degree

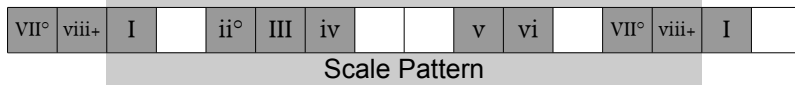

I	Min/Maj / Δ7/-Δ7/7/-7
II	°Sus2
III	Major / Δ7
IV	Min/Maj / Δ7/-Δ7/7/-7
V	Min/Maj / -6 / 6
VI	Min/Maj
VII	Major ° / °7
VIII	Min/Maj + / +Δ7 / +-Δ7

I	Σαμπάχ (Sabac)
II	
III	Σαμπάχ III
IV	
V	Σαμπάχ V/v
VI	Σαμπάχ VI/vi
VII	
VIII	

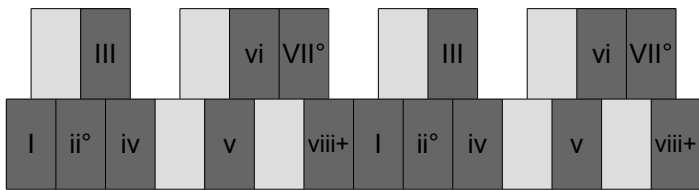

C Σαμπάχ

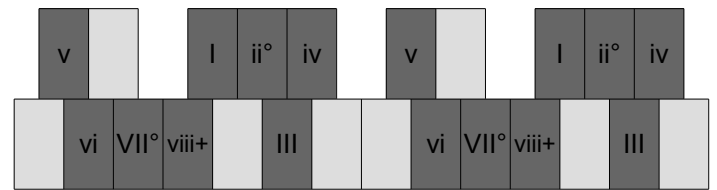

Gb Σαμπάχ

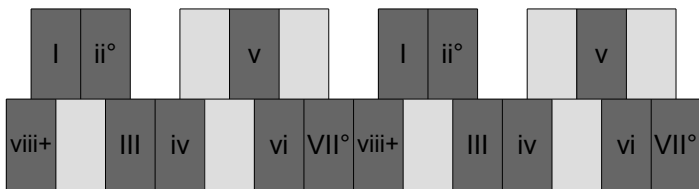

Db Σαμπάχ

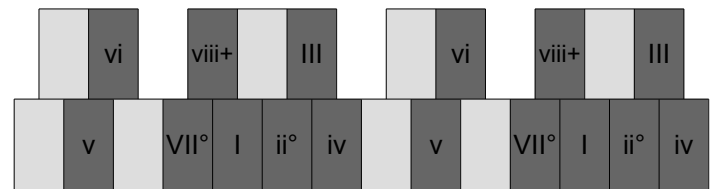

G Σαμπάχ

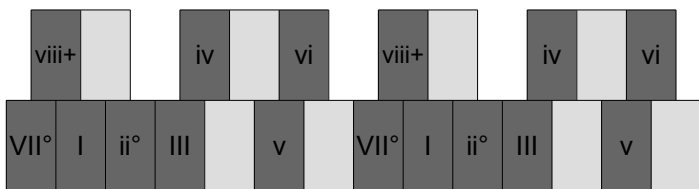

D Σαμπάχ

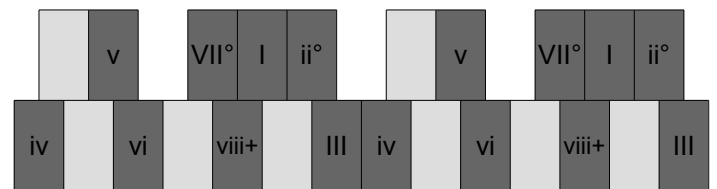

Ab Σαμπάχ

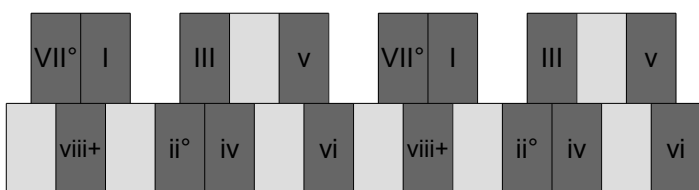

Eb Σαμπάχ

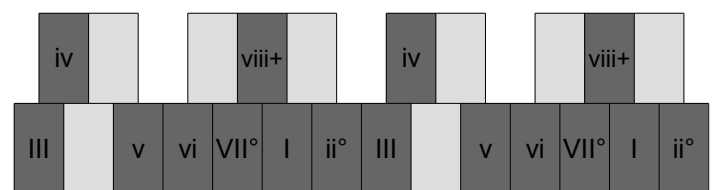

A Σαμπάχ

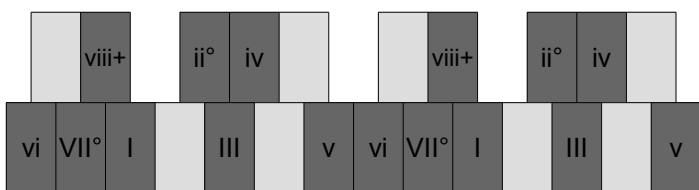

E Σαμπάχ

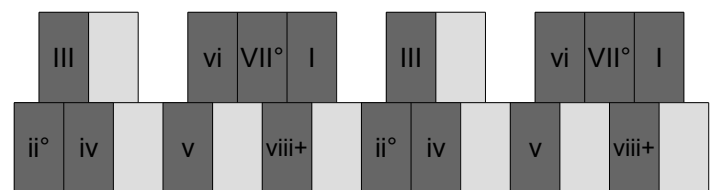

Bb Σαμπάχ

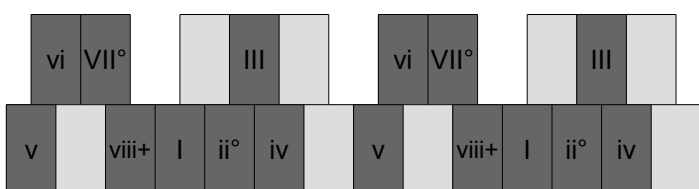

F Σαμπάχ

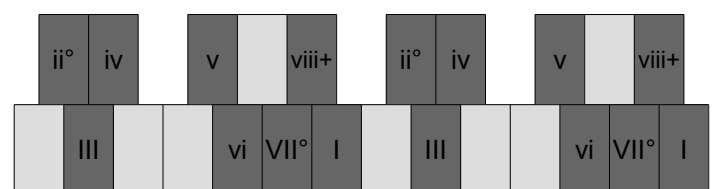

B Σαμπάχ

Ταρπαχανιώτικος / Pelog

Scale Degree

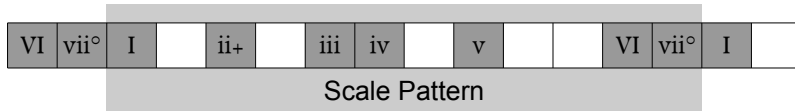

Equivalent mode

I	Major / 7 / Δ7
II	Minor + / +7
III	Minor / -7
IV	Sus2
V	Min/Maj / 7 / -7
VI	Major / 6
VII	Minor ° / °-Δ7

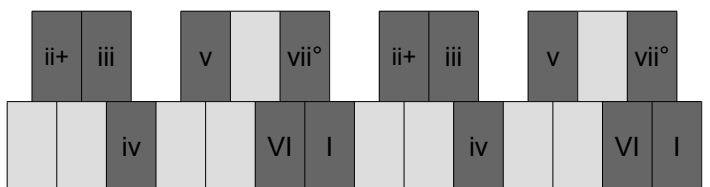
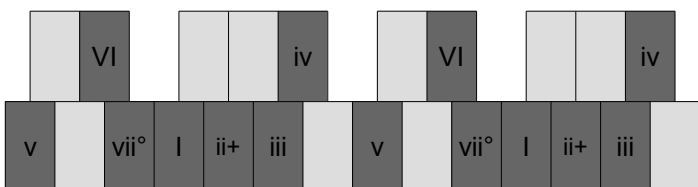
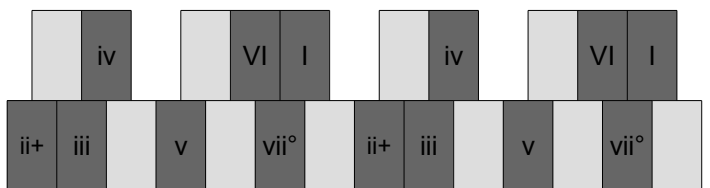
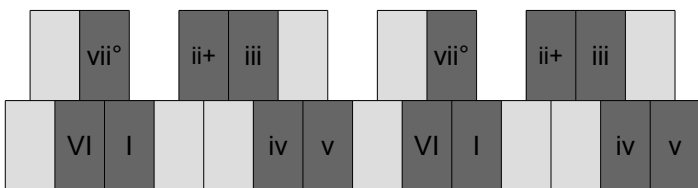
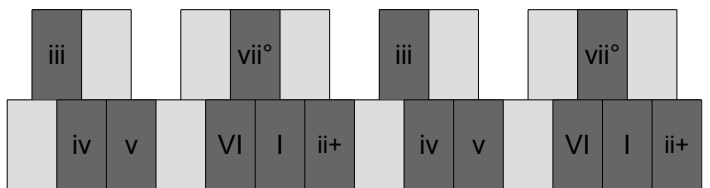
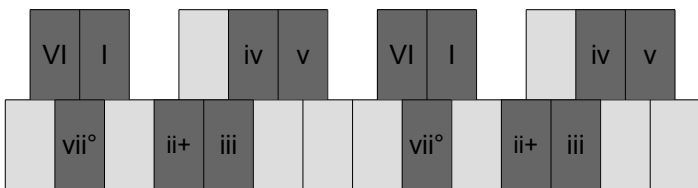
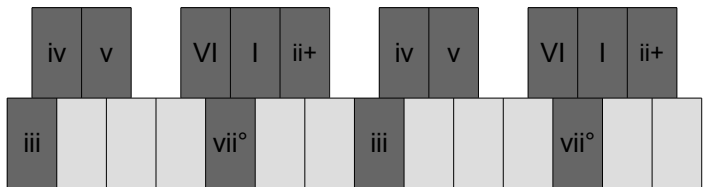
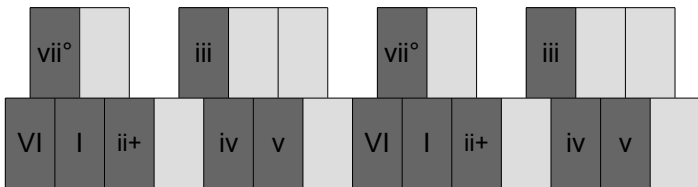
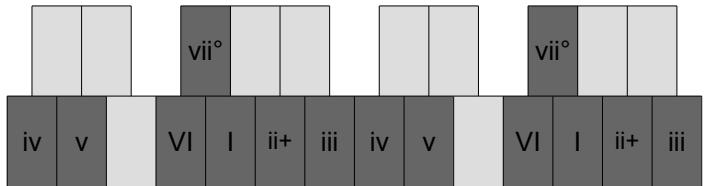
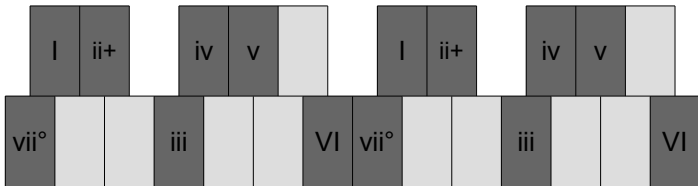
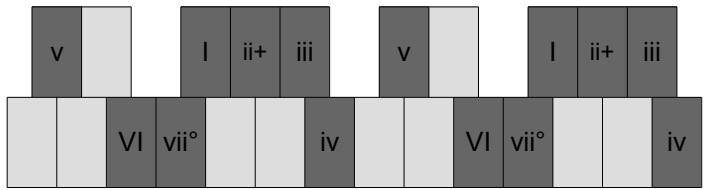
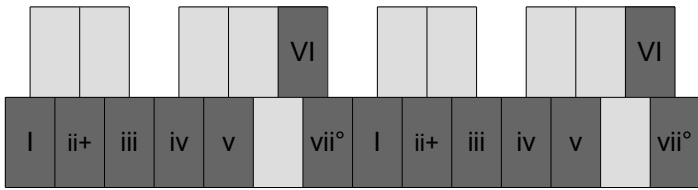
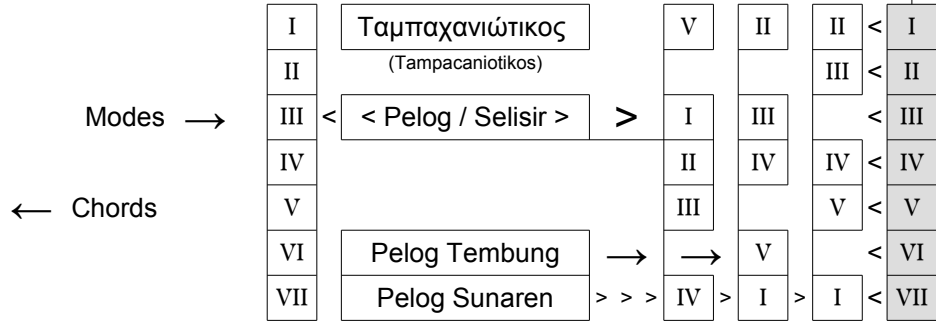

Σεγκιάχ (Segkiac) / Miaki Todi Raga

Scale Degree

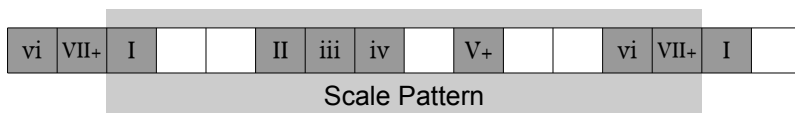

I	Min/Maj / Δ7/-Δ7/7-7
II	Major
III	Minor / -Δ7
IV	Sus2
V	Major + / +7 / +7
VI	Sus2
VII	Major + / +Δ7

Modes →
← Chords

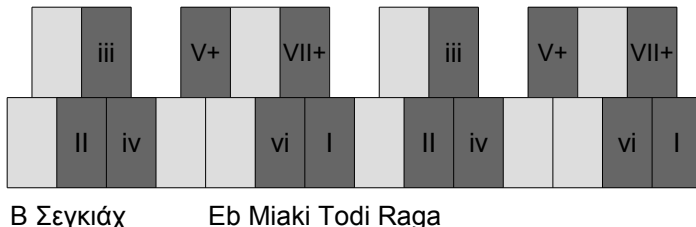
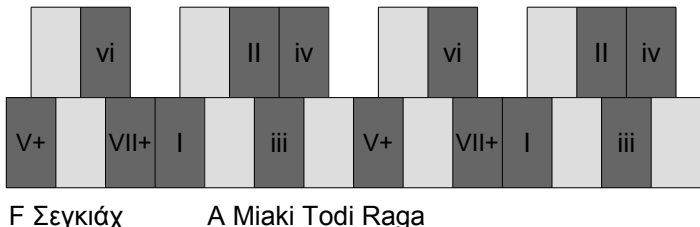
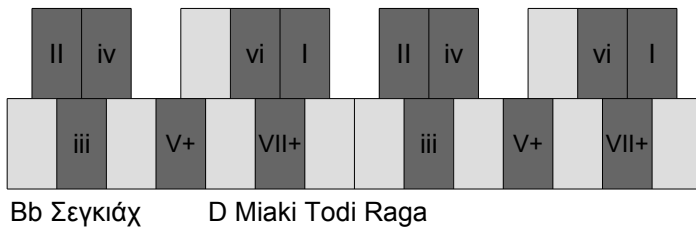
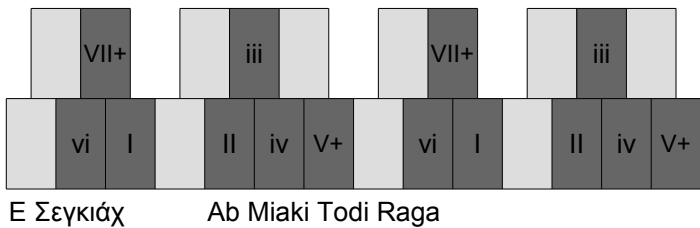
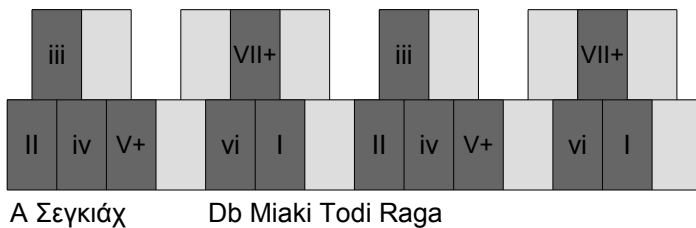
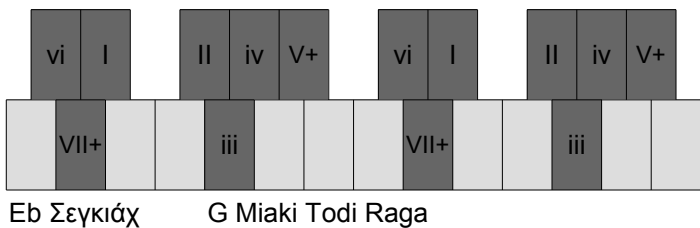
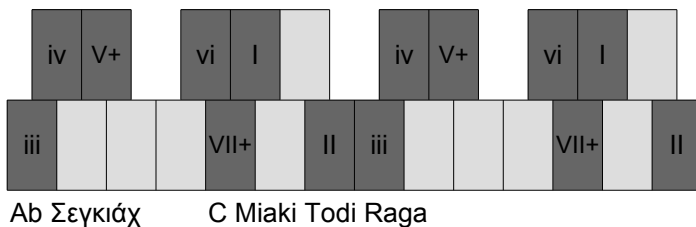
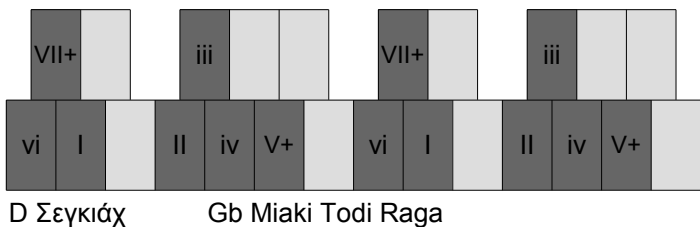
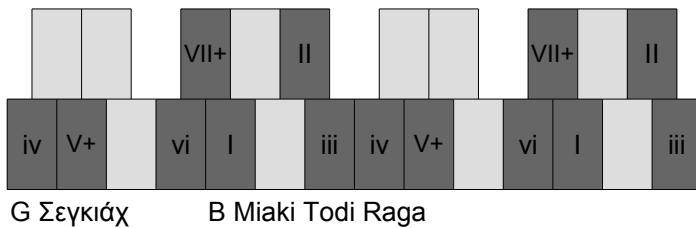
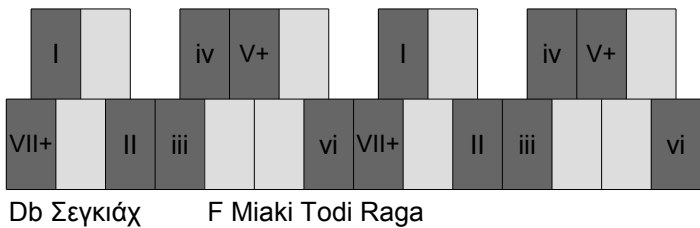
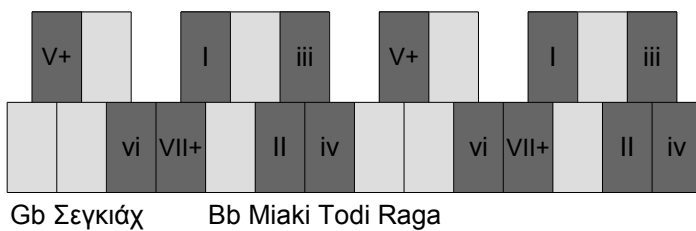
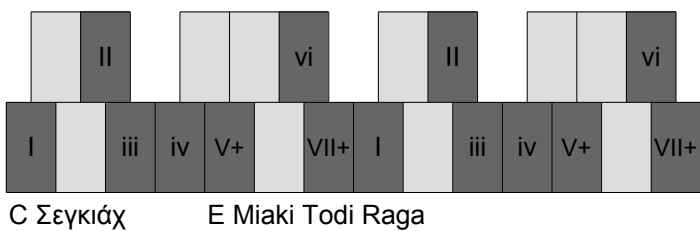
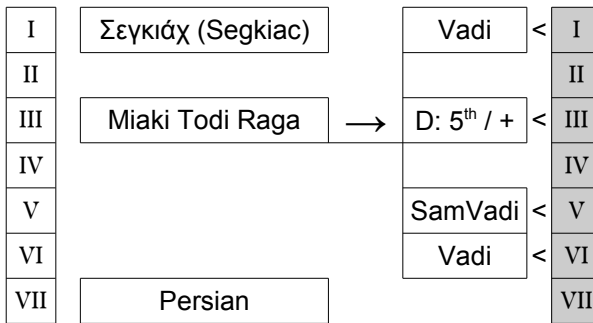

Marwa Raga / Blues Scale

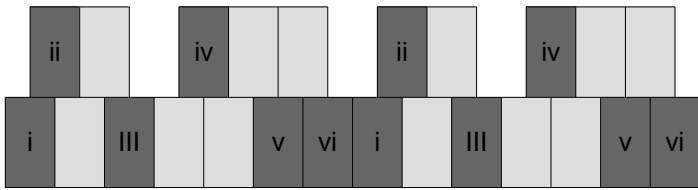
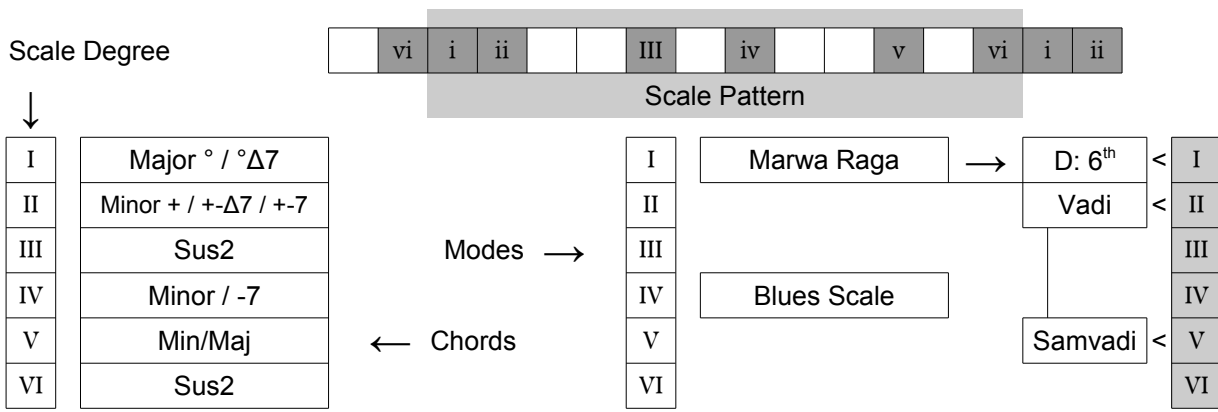

C Marwa Raga

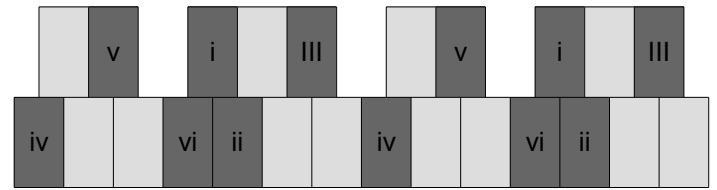

Gb Marwa Raga

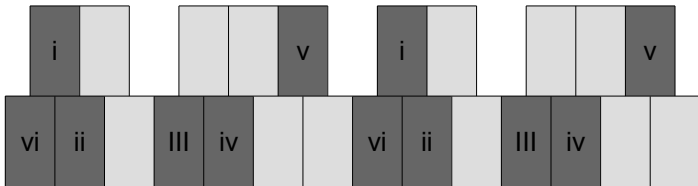

Db Marwa Raga

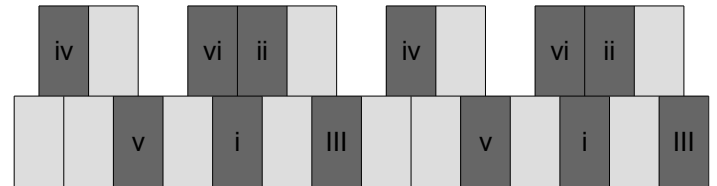

G Marwa Raga

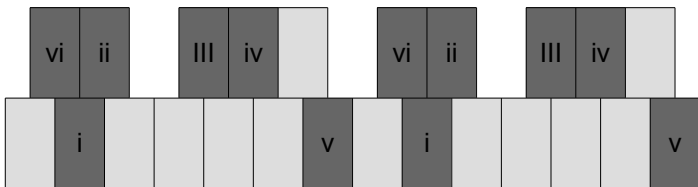

D Marwa Raga

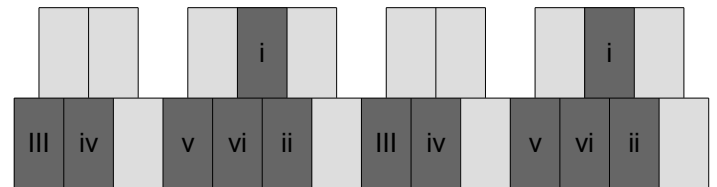

Ab Marwa Raga

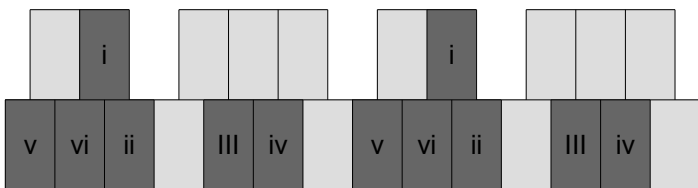

Eb Marwa Raga

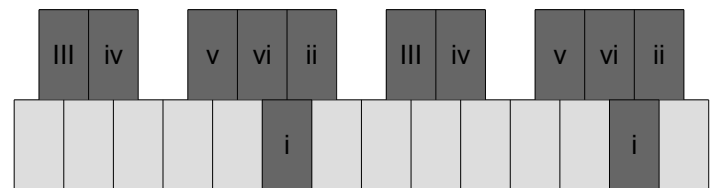

A Marwa Raga

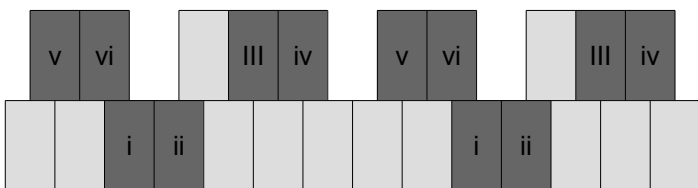

E Marwa Raga

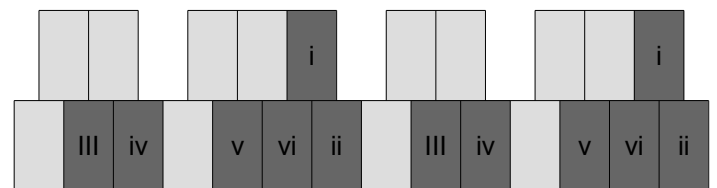

Bb Marwa Raga

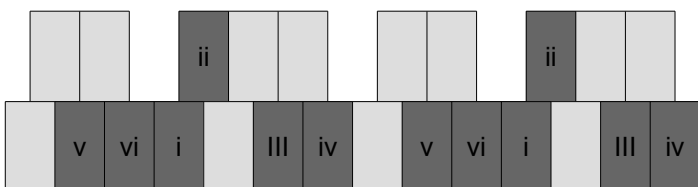

F Marwa Raga

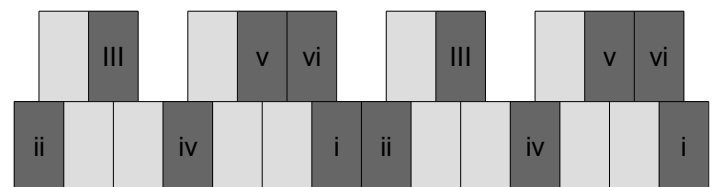

B Marwa Raga

Bahar Raga

Scale Degree

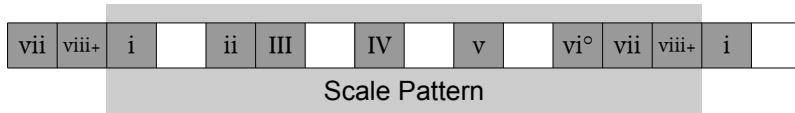

I	Minor / $-\Delta 7$ / -7
II	Minor / -7
III	Major / $\Delta 7$
IV	Major / 7
V	Min/Maj / -7 / 7
VI	Min $^\circ$ / $^\circ-7$
VII	Major / $\Delta 7$
VIII	Min/Maj+ / $+\Delta 7/+-\Delta 7/+7/+7$

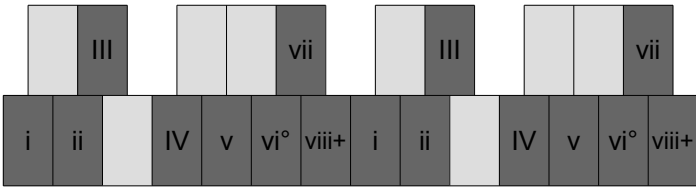
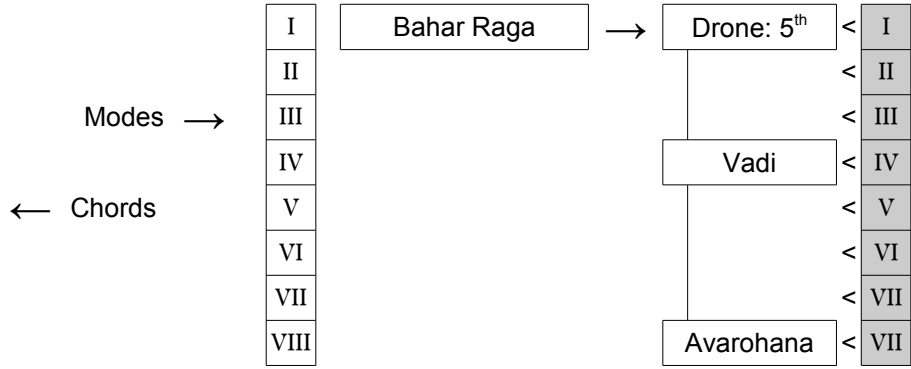

C Bahar Raga

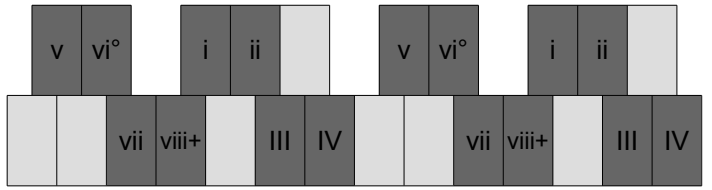

Gb Bahar Raga

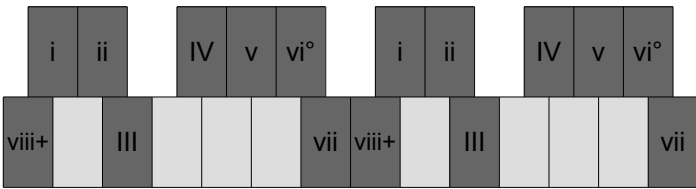

Db Bahar Raga

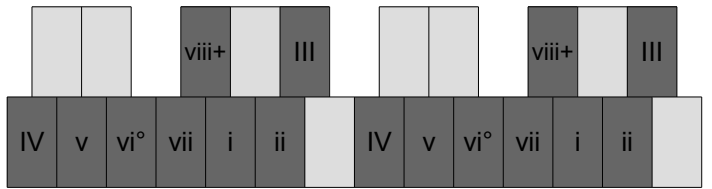

G Bahar Raga

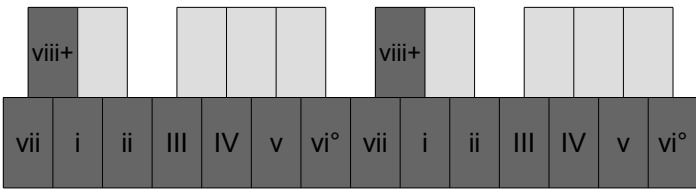

D Bahar Raga

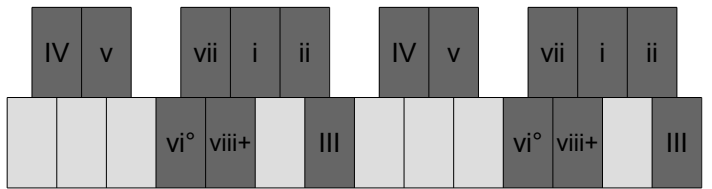

Ab Bahar Raga

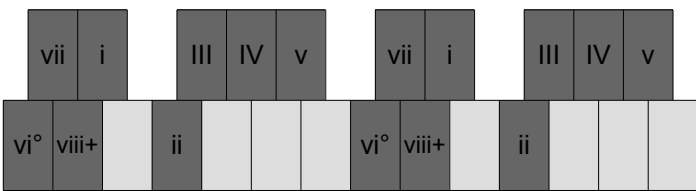

Eb Bahar Raga

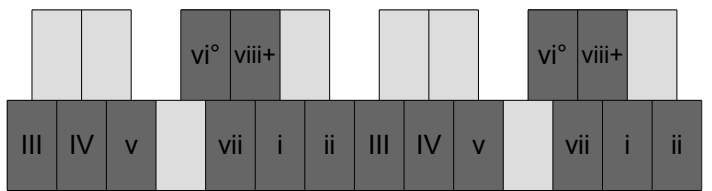

A Bahar Raga

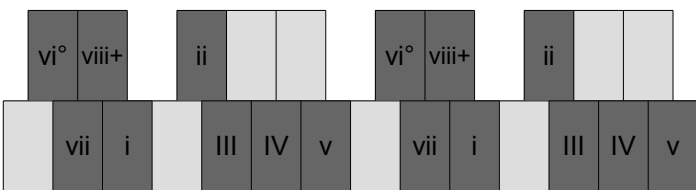

E Bahar Raga

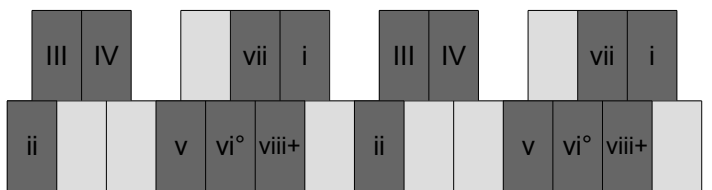

Bb Bahar Raga

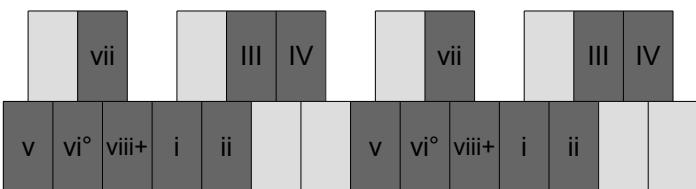

F Bahar Raga

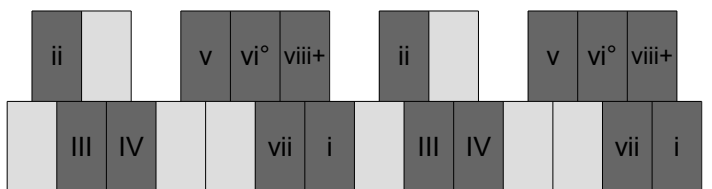

B Bahar Raga

Purvi Swar Raga / Lalith Raga

Scale Degree

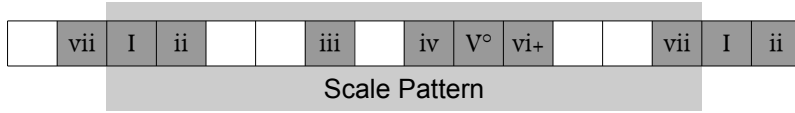

I	Major / Δ7
II	Minor / -Δ7 / -7
III	Min/Maj
IV	Sus2
V	Maj° / °7
VI	Min/Maj+ / +Δ7/+Δ7/+7/+7
VII	Sus2

Modes →
← Chords

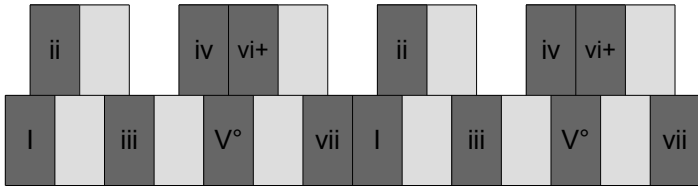
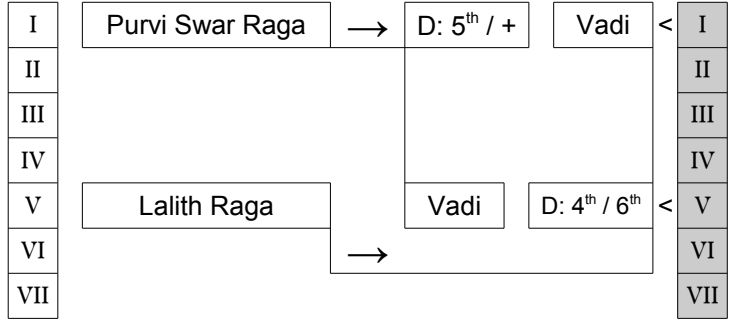

C Purvi Swar & Lalith Raga

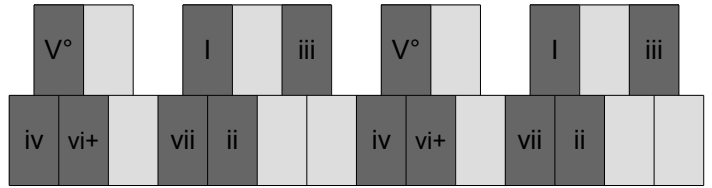

Gb Purvi Swar & Lalith Raga

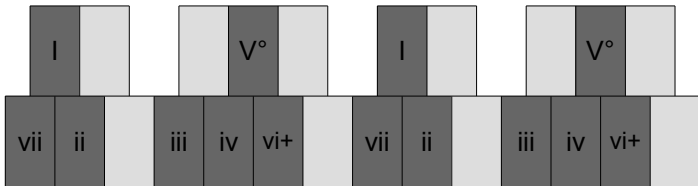

Db Purvi Swar & Lalith Raga

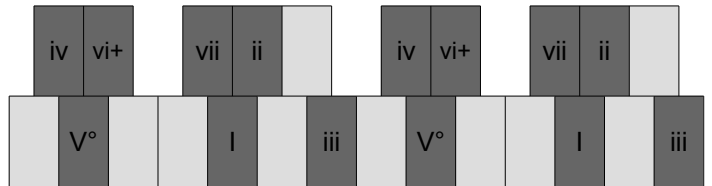

G Purvi Swar & Lalith Raga

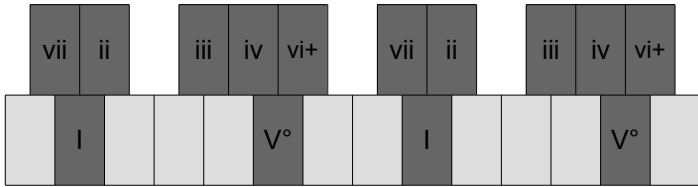

D Purvi Swar & Lalith Raga

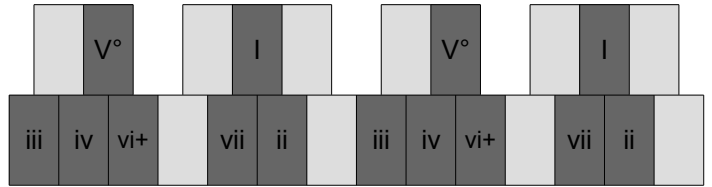

Ab Purvi Swar & Lalith Raga

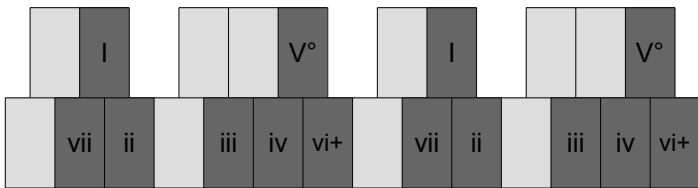

Eb Purvi Swar & Lalith Raga

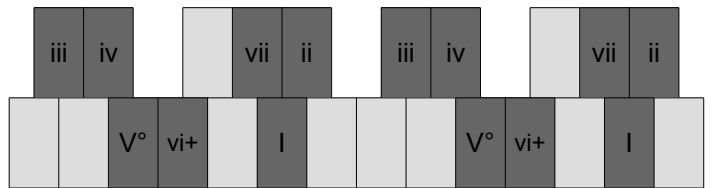

A Purvi Swar & Lalith Raga

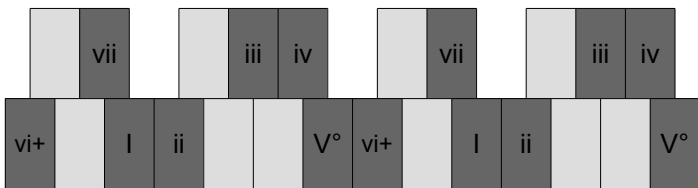

E Purvi Swar & Lalith Raga

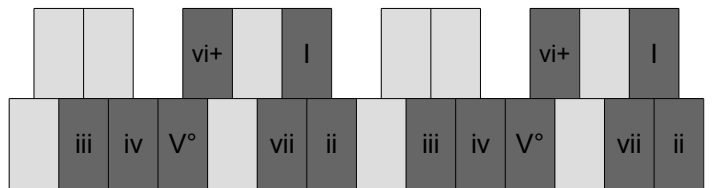

Bb Purvi Swar & Lalith Raga

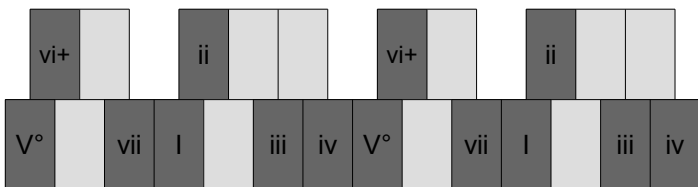

F Purvi Swar & Lalith Raga

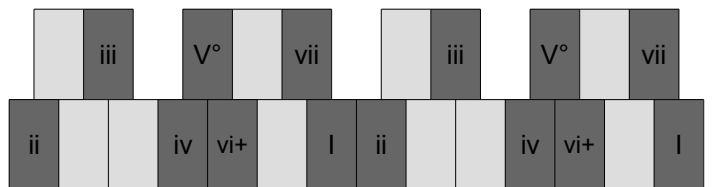

B Purvi Swar & Lalith Raga

Purvi Raga

Scale Degree

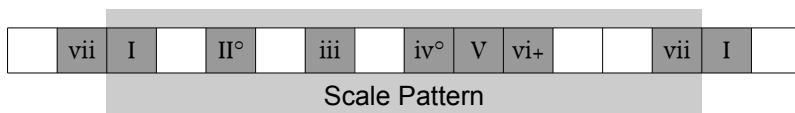

I	Major / $\Delta 7$
II	Major $^\circ$ / $^\circ 7$
III	Min/Maj / 7 / -7
IV	Sus2 $^\circ$
V	Major / 7
VI	Min/Maj+ / + $\Delta 7$ /+ $\Delta 7$ /+7/+7
VII	Minor

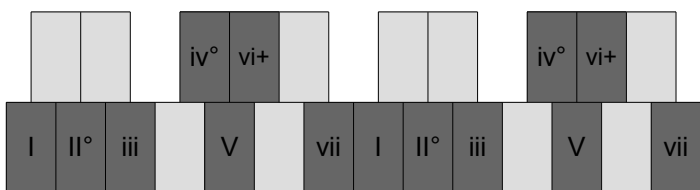
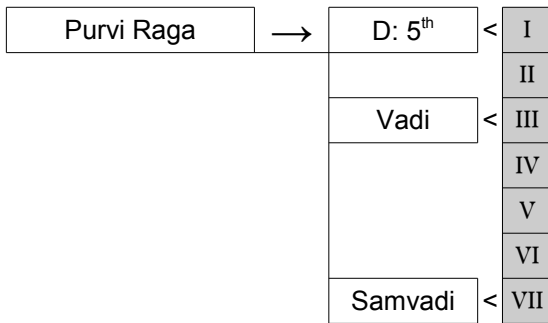
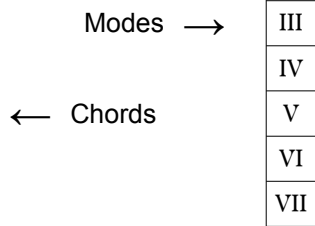

C Purvi Raga

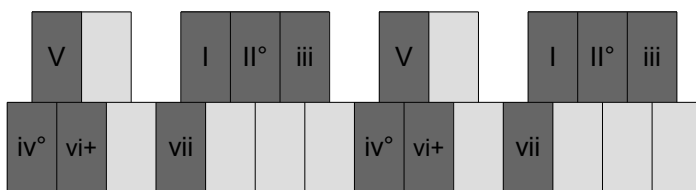

Gb Purvi Raga

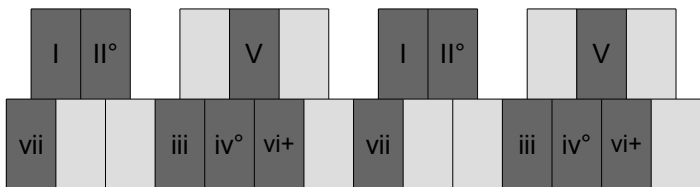

Db Purvi Raga

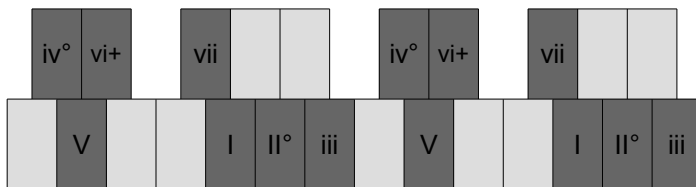

G Purvi Raga

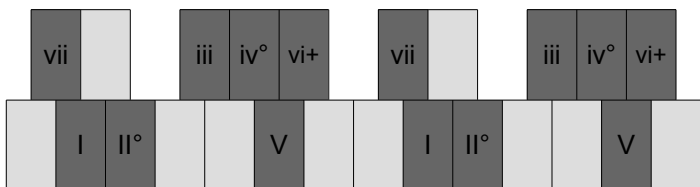

D Purvi Raga

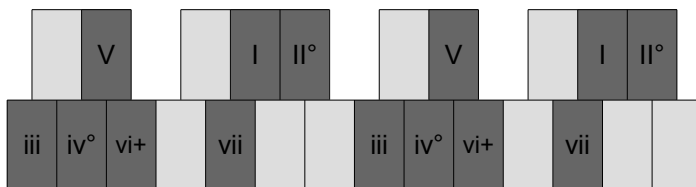

Ab Purvi Raga

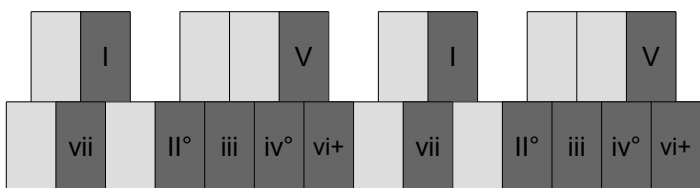

Eb Purvi Raga

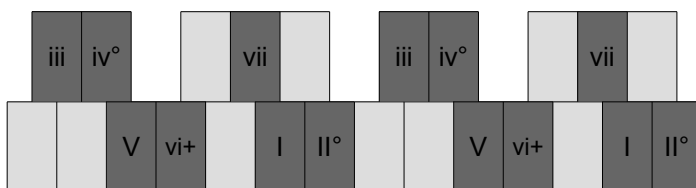

A Purvi Raga

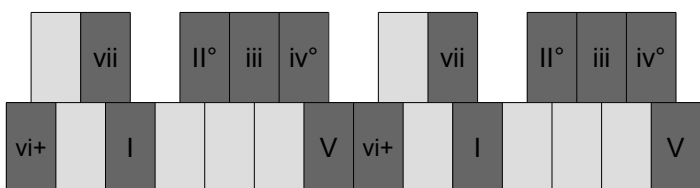

E Purvi Raga

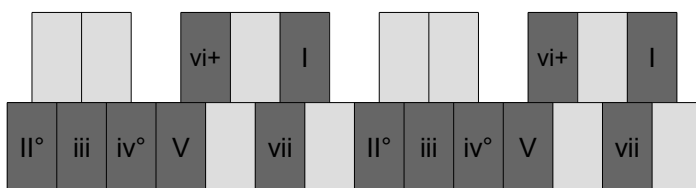

Bb Purvi Raga

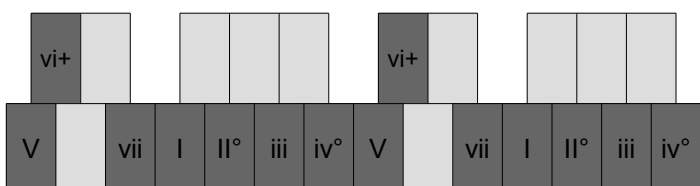

F Purvi Raga

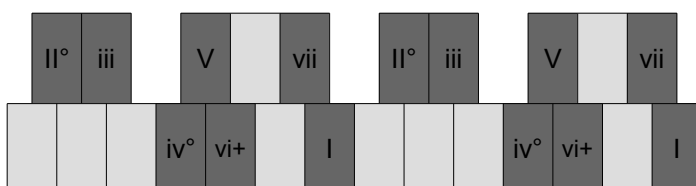

B Purvi Raga

Gujari Todi Raga

Scale Degree

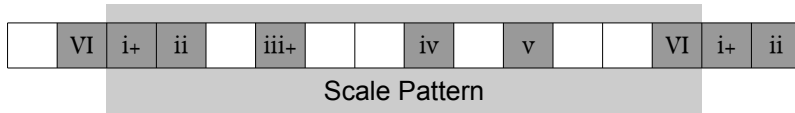

I	Minor +
II	Sus2
III	Minor + / +-7
IV	Sus2
V	Min/Maj / 7 / -7
VI	Major

Modes →
← Chords

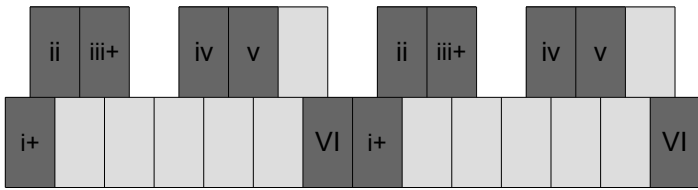
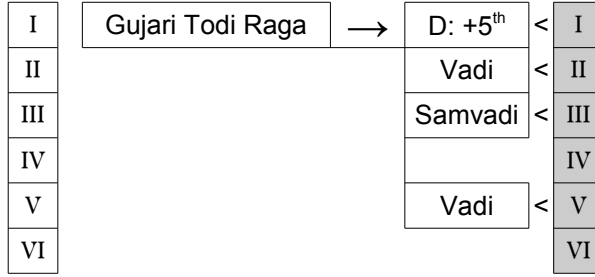

C Gujari Todi Raga

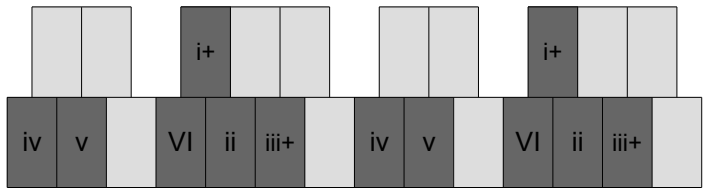

Gb Gujari Todi Raga

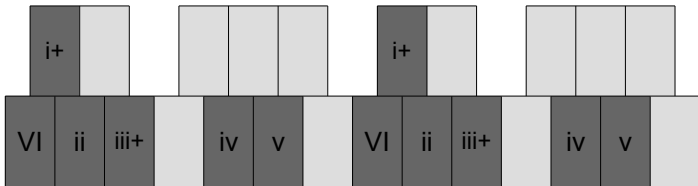

Db Gujari Todi Raga

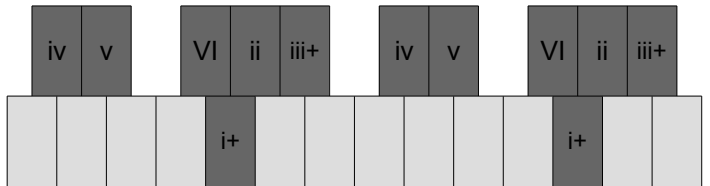

G Gujari Todi Raga

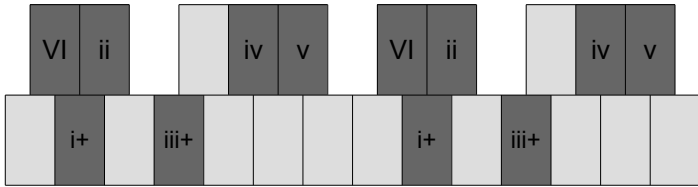

D Gujari Todi Raga

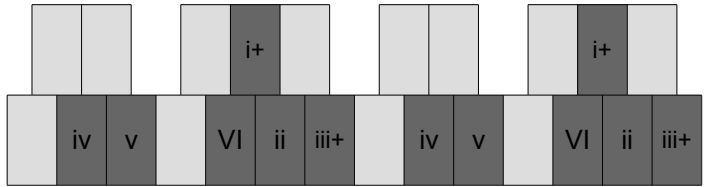

Ab Gujari Todi Raga

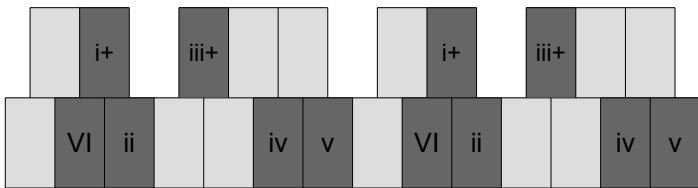

Eb Gujari Todi Raga

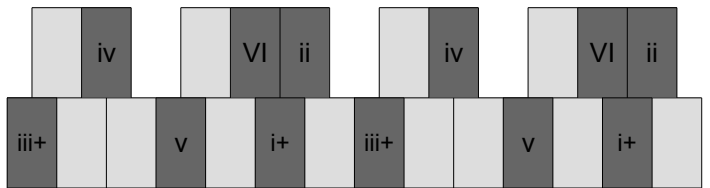

A Gujari Todi Raga

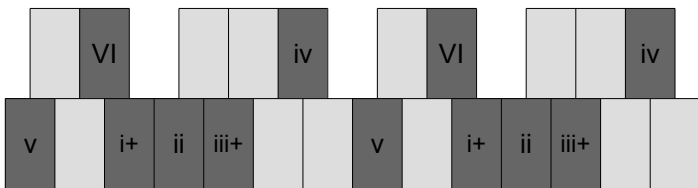

E Gujari Todi Raga

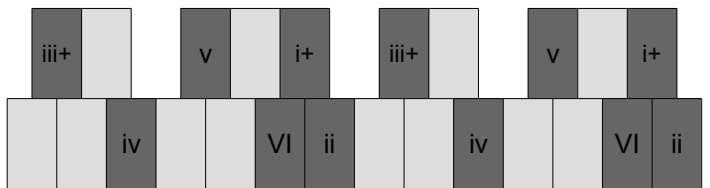

Bb Gujari Todi Raga

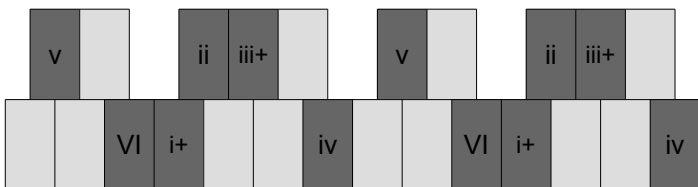

F Gujari Todi Raga

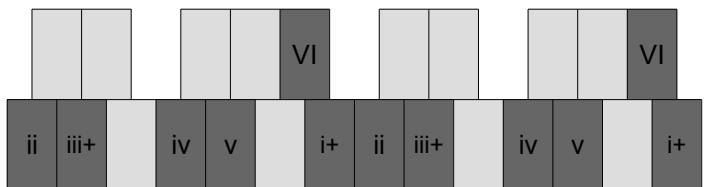

B Gujari Todi Raga